



19



313en19

p-BLOCK ELEMENTS AND THEIR COMPOUNDS – I

You have already studied the general characteristics of the p-block elements in the previous lesson. Now, we shall discuss some of the important elements and their compounds. Groups 13, 14 and 15 of the periodic table will be considered in this lesson and groups 16, 17 and 18 in the next lesson.



OBJECTIVES

After reading this lesson, you will be able to

- describe some general characteristics of Group 13, 14 and 15;
- describe the methods of preparation of boric acid, borax, diborane and boron trifluoride;
- explain the structure of diborane, boric acid and boron trifluoride;
- list the uses of borax, boric acid and boron trifluoride;
- list examples of double salts;
- describe the preparation and uses of aluminium trichloride and potash alum;
- explain the structure of aluminium trichloride;
- list the allotropes of crystalline carbon;
- compare the structures of diamond and graphite;
- explain the structure and properties uses of carbon monoxide, carbon dioxide and silicon dioxide;
- compare hydrolytic behaviour of carbon tetrachloride and silicon tetrachloride;
- describe preparation and uses of silicon carbide;

- describe silicones, silicates and zeolite;
- explain the preparation properties and uses of nitrogen;
- explain the processes for manufacture of ammonia and nitric acid;
- explain allotropic forms of phosphorus;
- list the properties and uses of ammonia and nitric acid;
- explain nitrogen fixation: natural and industrial and
- list a few nitrogenous, phosphatic and mixed fertilizers with their importance.



Notes

19.1 SOME GENERAL CHARACTERISTICS OF ELEMENTS OF GROUP 13

This group consists of B, Al, Ga, In and Tl.

All these elements exhibit a group valency of three, but because of the very large input of energy that is necessary to form the 3-valent ions—the sum of the first three ionisation energies—their compounds when anhydrous are either essentially covalent or contain an appreciable amount of covalent character. Boron never forms a B^{3+} ion since the enormous amount of energy required to remove three electrons from a small atom.

The electronic configurations of the boron and aluminium atoms are similar in as much as the penultimate shell has a noble gas configuration. whereas the penultimate shell of the gallium, indium and thallium atoms contains eighteen electrons. (Table 19.1)

Boron, which is non-metallic, and aluminium, which is clearly metallic, are best considered separately. Gallium, indium and thallium are weakly metallic.

Table 19.1: Physical properties of Group 13 elements

Atomic Number	Electronic Configuration	Ionisation Energy/ kJmol^{-1}			Standard Electrode Potential/V	Atomic Radius/nm	Ionic Radius/nm	M.P. /°C	B.P. /°C
		First	Second	Third					
B	2.3 $1s^2 2s^2 2p^1$	800	2427	3650		0.080 Estimated value	0.020	2300	3930
Al	2.8.3 $\dots 2s^2 2p^6 3s^2 3p^1$	578	1816	2744	-1.66	0.125	0.050	660	2470
Ga	2.8.18.3 $\dots 3s^2 3p^6 3d^{10} 4s^2 4p^1$	579	1979	2962	-0.52	0.125	0.062	29.8	2400
In	2.8.18.18.3 $\dots 4s^2 4p^6 4d^{10} 5s^2 5p^1$	558	1820	2705	-0.34	0.150	0.081	157	2000
Tl	2.8.18.32.18.3 $\dots 5s^2 5p^6 5d^{10} 6s^2 6p^1$	589	1970	2880	+0.72	0.155	0.095	304	1460

Occurrence and Abundance

Boron is a fairly rare element, but it is well known because it occurs as concentrated deposits of borax $\text{Na}_2\text{B}_4\text{O}_7 \cdot 10\text{H}_2\text{O}$ and kernite $\text{Na}_2\text{B}_4\text{O}_7 \cdot 4\text{H}_2\text{O}$.

Aluminium is the most abundant metal, and the third most abundant element (after oxygen and silicon) by weight in the earth's crust (Table 19.2). It is well known and is commercially important. Aluminium metal is produced on a vast scale. Primary production was 17.6 million tonnes, and an additional 4 million tonnes is recycled. The most important ore of aluminium is bauxite. This is a generic name for several minerals with formulae varying between $\text{Al}_2\text{O}_3 \cdot \text{H}_2\text{O}$ and $\text{Al}_2\text{O}_3 \cdot 3\text{H}_2\text{O}$.

**Notes****Table 19.2: Abundance of the elements in the earth's crust by weight**

	ppm	Relative abundance
B	9	38
Al	83000	3
Ga	19	33
In	0.24	63
Tl	0.5	60

Gallium is twice as abundant as boron, but indium and thallium are much less common. All three elements, Ga, In and Tl, occur as sulphides. Ga, In and Tl are not very well known.

18.1.1 Boron

Boron can be obtained as an amorphous brown powder by treating borax with hydrochloric acid, igniting the boric acid, H_3BO_3 obtained, to give the oxide, B_2O_3 , and finally reducing the latter with magnesium at a high temperature:

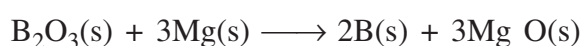

It is used in the construction of high impact-resistant steel and, since it absorbs neutrons, in reactor rods for controlling atomic reactions.

A crystalline form of boron can be obtained by thermal decomposition of boron tri-iodide on a tantalum filament:

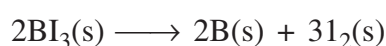

Properties of boron

Amorphous boron is a very reactive element combining directly with oxygen, sulphur, nitrogen and the halogens to give respectively, an oxide, sulphide, nitride and a halide.

Reactions of Boron

Pure crystalline boron is very unreactive. However, it is attacked at high temperatures by strong oxidizing agents such as a mixture of hot concentrated H_2SO_4 and HNO_3 , or by sodium peroxide. In contrast, finely divided amorphous boron (which contains between 2% and 5% of impurities) is more reactive. It burns in air or oxygen, forming the oxide. It also burns at white heat in nitrogen, forming the nitride BN. This is a slippery white solid with a layer structure similar to graphite. Boron also burns in the halogens, forming trihalides. It reacts directly with many metals, forming borides, which are hard and refractory. It reduces strong HNO_3 and H_2SO_4 slowly, and also liberates H_2 from fused NaOH . At red heat it will reduce steam to hydrogen:

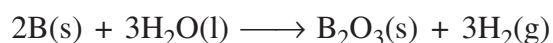
**Some reactions of amorphous boron**

Reaction	Comment
$4\text{B} + 3\text{O}_2 \rightarrow 2\text{B}_2\text{O}_3$	At high temperature
$4\text{B} + 3\text{S} \rightarrow \text{B}_2\text{S}_3$	At 1200°C
$2\text{B} + \text{N}_2 \rightarrow 2\text{BN}$	At very high temperature
$2\text{B} + 3\text{F}_2 \rightarrow 2\text{BF}_3$	At high temperature
$2\text{B} + 3\text{Cl}_2 \rightarrow 2\text{BCl}_3$	
$2\text{B} + 3\text{Br}_2 \rightarrow 2\text{BBr}_3$	
$2\text{B} + 3\text{I}_2 \rightarrow 2\text{BI}_3$	
$2\text{B} + 6\text{NaOH} \rightarrow 2\text{Na}_3\text{BO}_3 + 3\text{H}_2$	When fused with alkali
$2\text{B} + 2\text{NH}_3 \rightarrow 2\text{BN} + 3\text{H}_2$	At very high temperature
$\text{B} + \text{M} \rightarrow \text{M}_x\text{B}_y$	Many metals form borides (not group I) often nonstoichiometric



Notes

Reactions of Aluminium

Reaction with water and air

Thermodynamically Al should react with water and with air, but in fact, it is stable in both. The reason is that a very thin oxide film forms on the surface which protects the metal from further attack. This layer is only 10^{-4} to 10^{-6} mm thick. If the protective oxide covering is removed, for example by amalgamating with mercury, then the metal readily decomposes cold water, forming Al_2O_3 and liberating hydrogen.

Aluminium articles are often 'anodized' to give a decorative finish. This is done by electrolysing dilute H_2SO_4 with the aluminium as the anode. This produces a much thicker layer of oxide on the surface (10^{-2} mm). This layer can take up pigments, thus colouring the aluminium.

Aluminium burns in nitrogen at high temperatures, forming AlN .

Reaction with acids and alkalis

Aluminium dissolves in dilute mineral acids liberating hydrogen.



However, concentrated HNO_3 renders the metal passive because it is an oxidizing agent, and produces a protective layer of oxide on the surface. Aluminium also dissolves in aqueous NaOH (and is therefore amphoteric), liberating hydrogen and forming aluminates.

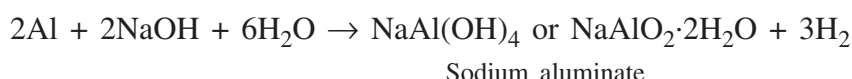

Uses of aluminium

1. As structural metals in aircraft, ships, cars, and heat exchangers.
2. In buildings (doors, windows, cladding panels and mobile homes).
3. Container such as cans for drinks, tubes for toothpaste etc. and metal foil.
4. For cooking utensils.
5. To make electric power cables (on a weight for weight basis they conduct twice as well as copper).
6. Finely divided aluminium powder is called 'aluminium bronze', and is used in preparing aluminium paint.



Notes

19.2 COMPOUND BORON AND ALUMINIUM

Boron and aluminium are the first two members of Group 13 of the periodic table. Though the outermost electronic configurations of boron and aluminium are similar yet there is a big difference between the properties of their compounds. This will become clear when we study the compounds of boron and aluminium.

19.2.1 Boric Acid

Preparation : Boric acid (also called orthoboric acid) H_3BO_3 , $[\text{B}(\text{OH})_3]$ is prepared by the action of sulphuric acid on concentrated solution of borax ($\text{Na}_2\text{B}_4\text{O}_7 \cdot 10\text{H}_2\text{O}$). Boric acid separates as white flaky crystals.



Properties and Structure : Boric acid is a white crystalline solid. It is soluble in water. It behaves as a weak Lewis acid rather than a protonic acid because it combines with hydroxyl ions (OH^-) of water to liberate hydronium ions (H_3O^+). Thus

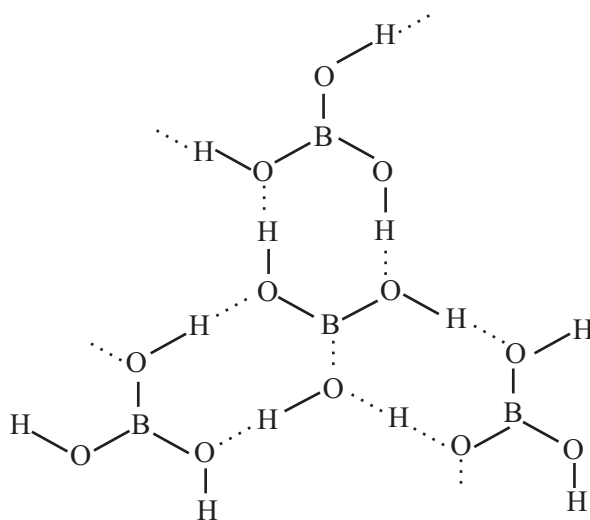
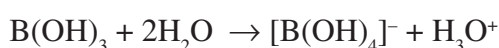
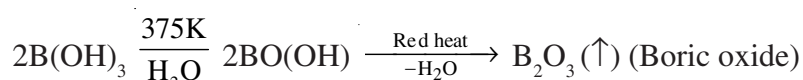

Fig. 19.1: Structure of boric acid; the dotted lines represent hydrogen bonds

When heated, it decomposes to metaboric acid and finally to boric anhydride (or boric oxide) at red heat



In boric acid, $\text{B}(\text{OH})_3$ units are linked by hydrogen bonds to give two dimen-



Notes

sional sheets (Fig. 19.1). The sheets are held together by weak van der Waals forces which are responsible for the cleavage of solid structure into flakes.

Uses: Boric acid is used:

- (i) as an antiseptic,
- (ii) as a food preservative, and
- (iii) in making enamels, pottery glazes and glass.

19.2.2 Borax, $\text{Na}_2\text{B}_4\text{O}_7 \cdot 10\text{H}_2\text{O}$

In crude form borax occurs as *tincal* in dried up lakes of India. It is also prepared from the mineral colemanite, $\text{Ca}_2\text{B}_6\text{O}_{11}$ by the action of concentrated solution of sodium carbonate



Borax is crystallised from the filtrate. Borax is a white crystalline solid of the formula $\text{Na}_2\text{B}_4\text{O}_7 \cdot 10\text{H}_2\text{O}$. On heating it loses water of crystallisation.

It is used:

- (i) as an alkaline buffer in dyeing and bleaching processes
- (ii) as a preservative
- (iii) in the manufacture of optical and borosilicate glasses
- (iv) as a flux, and
- (v) in making glazes for pottery and tiles.

19.2.3 Diborane, B_2H_6

Diborane is the most important hydride of boron.

Preparation:

It is prepared by the following methods:

- (i) By the action of lithium aluminium hydride on boron trichloride



- (ii) By the action of lithium hydride on boron trifluoride

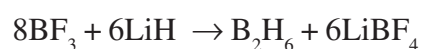

Notes

Properties:

- Diborane is a toxic gas and has a foul smell.
- It burns in oxygen to give enormous amount of energy.

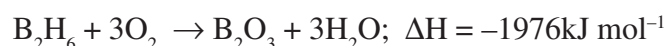

- It is readily hydrolysed by water

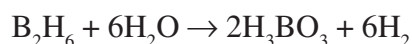

Structure : The molecular structure of diborane is shown below. The two boron atoms and the four terminal hydrogen atoms lie in one plane, the two bridging hydrogen atoms lie symmetrically above and below the plane. If we consider the bonding situation in B_2H_6 , there are eight B–H bonds but only twelve valence electrons. Obviously there are not enough electrons to fill all the available orbitals to form eight normal covalent (two-centre) bonds. Thus bonding in diborane is described in terms of two multi centre bonds, i.e., 3c–2e or three centre two electron B–H–B bonds and four normal B–H bonds.

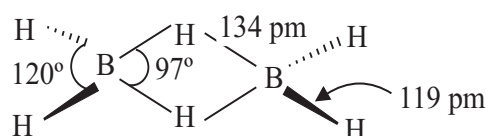
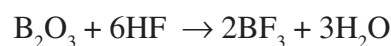

Fig. 19.2 : Structure of diborane, B_2H_6

19.2.4 Boron Trifluoride

Boron forms halides BX_3 ($\text{X} = \text{F}, \text{Cl}, \text{Br}, \text{I}$). All these halides with exception of fluoride, are formed by the action of appropriate halogen on boric oxide at high temperature. Boron trifluoride is formed by the action of hydrofluoric acid on boron oxide. Thus



BF_3 hydrolyses according to the following equation

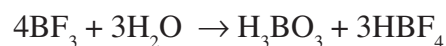

BF_3 acts as an electron acceptor (Lewis acid) since B does not have an octet of electrons in its valence shell; infact it has a sextet. It forms complexes with nitrogen and oxygen donors, e.g. NH_3 and ether, thus completing the octet of boron.



Boron trifluoride is used as a catalyst in Friedel-Crafts reaction such as alkylation and acylation and in polymerization reactions.



Notes

The structure of boron trifluoride is shown in Fig 19.3:

B–F bond in BF_3 has a multiple bond character since its structure is a resonance hybrid of three resonating structures.

Note that in the resonating structures boron completes its octet.

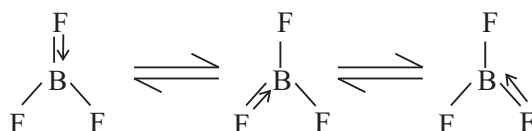
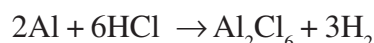

Fig 19.3 : Resonating structures of boron trifluoride

19.2.5 Aluminium trichloride

Aluminium trichloride exists as a dimer as Al_2Cl_6 at room temperature and as a monomer at high temperatures and is made by passing hydrogen chloride or chlorine over heated aluminium under anhydrous condition.



When pure, it is a white solid which sublimes at 453K. Aluminium has only three valence electrons. When these are used to form three covalent bonds, the atom has only six electrons in its valence shell. Since it is electron deficient it, therefore, exists as a dimer. The aluminium atoms complete their octets by dative bonding from two chlorine atoms. The arrangement of chlorine atoms about each aluminium atom is roughly tetrahedral. The structure of the dimer is shown in Fig. 19.4.

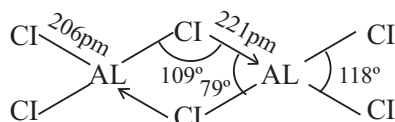

Fig.19.4 : Structure of AlCl_3

When treated with water it gives hydrated aluminium ions and Cl^- ions:



Anhydrous aluminium chloride is used as a catalyst in Friedel-Crafts reaction because of its Lewis acid character.

19.2.6 Double Salts: Alums and Potash Alum

When two salts capable of independent existence are mixed and the solution of the mixture is allowed to crystallise, crystals comprising both the salts are characteristically formed. However, in solution all the ions exist freely. Such substances



Notes

are called double salts. For example, when a solution containing potassium sulphate and aluminium sulphate is allowed to crystallise, transparent octahedral crystals of potash alum, $K^+ Al^{3+} (SO_4^{2-})_2 \cdot 12 H_2O$ are obtained. The solid contains $[K(H_2O)_6]^+$, $[Al(H_2O)_6]^{3+}$ and SO_4^{2-} ions and it is a double salt since it gives the tests of its constituent ions in solutions. The double sulphate with similar composition and properties are called alums.

It is possible to replace the trivalent aluminium cation by trivalent metal ion of the similar ionic size, e.g. Ti^{3+} , Cr^{3+} , Fe^{3+} and Co^{3+} . It is also possible to prepare a series of alums in which potassium ion is replaced by ammonium ion, NH_4^+ .

The alums are isomorphous, a few typical ones are given below:



Potash alum, $K Al (SO_4)_2 \cdot 12H_2O$, is by far the most important of all the alums. It is used as a mordant in dyeing industry and also in purifying water. (Often it is formulated as $K_2SO_4 \cdot Al_2 (SO_4)_3 \cdot 24 H_2O$).



INTEXT QUESTIONS 19.1

- Write the formula of the following:
(i) Boric acid (ii) Borax
- Write one reaction for the preparation of diborane.
- What is the general formula of alums?
- Write the formula of anhydrous solid aluminium trichloride and its structure.
- Mention one use each of
(i) borax (ii) boric acid (iii) boron trifluoride
- Why aluminium become non-reactive after reacting with HNO_3 .
- Orthoboric acid is monoprotic or triprotic.

19.3 SOME GENERAL REMARKS ABOUT GROUP 14

All these elements exhibit a group valency of four, but because an enormous amount of energy is needed to remove four electrons from their atoms, they form compounds which are predominantly covalent. Similarly the gain of four electrons to give the 4-valent anion is energetically impossible.



Notes

Germanium, tin and lead form 2-valent compounds in which the two s electrons are inert (inert pair effect). The stability of this state relative to the 4-valent state increases steadily from germanium to lead, i.e. 2-valent germanium compounds tend to be strongly reducing and revert to the 4-valent state, while for lead this is the predominant valency state. 2-valent compounds of tin and lead are often predominantly ionic.

Carbon is non-metallic and so too is silicon; germanium has properties of both metals and non-metals (it is a metalloid), while the elements tin and lead are definitely metallic. There is a smooth transition from non-metallic to metallic properties on passing down the series silicon, germanium, tin and lead, but the first member carbon differs considerably from silicon. The chemistry of silicon is very similar to that of boron, its diagonal neighbour in the Periodic Table.



Notes

Table 19.3: Physical properties of Group-14 elements

	Atomic Number	Electronic Configuration	Atomic Radius/nm	Ionic Radius/nm		M.P. /°C	B.P. /°C
				M ²⁺	M ⁴⁺		
C	6	2.4 1s ² 2s ² 2p ²	0.077				3580 (subl.)
Si	14	2.8.4 ...2s ² 2p ⁶ 3s ² 3p ²	0.117		0.041	1410	2360
Ge	32	2.8.18.4 ...3s ² 3p ⁶ 3d ¹⁰ 4s ² 4p ²	0.122	0.093	0.053	937	2830
Sn	50	2.8.18.18.4 ...4s ² 4p ⁶ 4d ¹⁰ 5s ² 5p ²	0.140	0.112	0.071	232	2270
Pb	82	2.8.18.18.8.4 ...5s ² 5p ⁶ 5d ¹⁰ 6s ² 6p ²	0.154	0.120	0.084	237	1744

The chemistry of carbon is dominated by its tendency to form chains and rings of carbon atoms in which other atoms, particularly hydrogen, play an important part. The chemistry of silicon is completely different.

Chemical properties of carbon

Carbon in any form will react with oxygen at a sufficiently high temperature to give carbon dioxide; in a deficiency of oxygen, carbon monoxide is formed as well. Charcoal will combine directly with sulphur, some metals and fluorine.

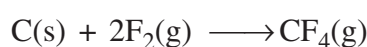
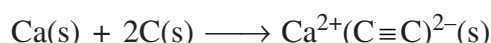
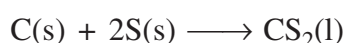

It will reduce steam, forming water gas and many oxides of metals; these reductions are of industrial importance.

It is not attacked by dilute acids, but concentrated nitric acid and sulphuric acid are reduced if warmed with carbon according to the equations

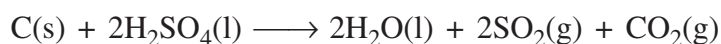
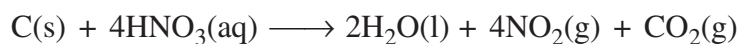

19.4 CARBON AND SILICON

Carbon and silicon belong to Group 14 of the periodic table. Both elements show significant differences in their chemistry. There are thousands of hydrocarbons (alkanes and other compounds of carbon and hydrogen) but only a few silanes (compounds of silicon and hydrogen are known). It is because carbon has the unique ability to form compounds in which the carbon atoms are bonded to each other in chains or rings. This property is called *catenation* which is due to the fact that C–C bond is much stronger than Si–Si bond.

19.4.1 Allotropic Forms of Carbon

Diamond and Graphite : Structures and Properties

Diamond and graphite, both are crystalline forms of carbon. But they are structurally different. Due to the difference in the arrangement of carbon atoms, they show different properties. In diamond, each carbon atom is sp^3 hybridized and is linked to four other carbon atoms by strong covalent bonds in a tetrahedral fashion. It gives rise to a three-dimensional arrangement (Fig.19.5). On the other hand, in graphite, the carbon atoms are arranged in layers. In each layer a particular carbon atom is sp^2 hybridized and is linked to three other carbon atoms in a hexagonal arrangement. The fourth electron is free and does not participate in bonding. The different layers are held together by weak van der Waals forces (Fig 19.6).

Chemically speaking diamond is unreactive and burns in oxygen only if heated above 800°C , forming carbon dioxide. It reacts with fluorine (but not with chlorine) at 973 K giving carbon tetrafluoride. Alkalies and acids have no action on diamond. It is the hardest natural substance.

Graphite, on the other hand, is reactive. It burns in air at 873 K to form CO_2 . It is not attacked by dilute acids but concentrated sulphuric acid reacts with graphite to give graphite bisulphate in solution. It does not react with chlorine also.

Diamond is used for cutting and grinding hard substances such as rocks, glass, etc., and in die for drawing wire for watch springs and lamp filaments. Beside all these, diamond is widely used in jewellery.



Notes

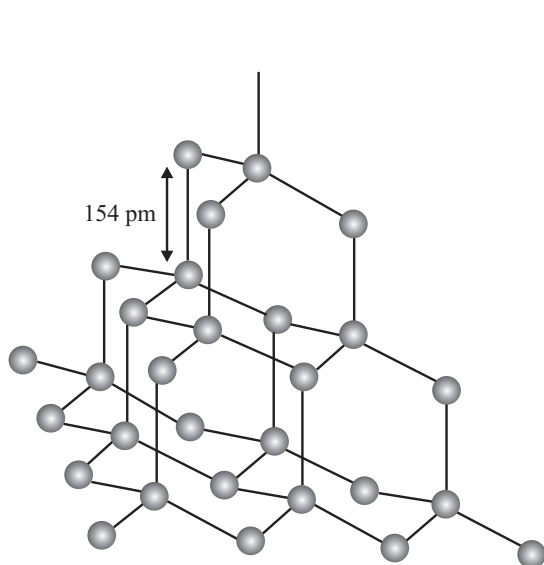

Fig. 19.5 : Structure of diamond

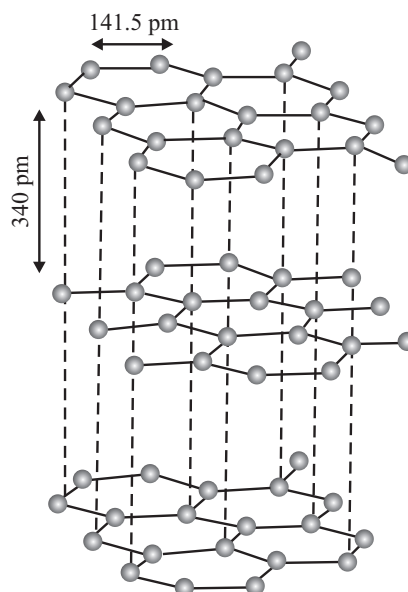

Fig. 19.6 : Structure of graphite

Graphite is used as electrodes, as lubricant, for making crucibles, for casting of metals, for lead pencils and as a constituent of heat resistant paints.

Fullerenes

Fullerene, a newly discovered allotrope of carbon is called “Buckminster Fullerene” after the name of American architect Buckminster Fuller. The most common Fullerene molecule has 60 carbon atoms and the carbon atoms are linked to create the shape of a hollow soccer ball. The outer surface of fullerenes can be altered by chemical reactions.

19.4.2 Oxides of Carbon and Silicon

Structure

Carbon forms two oxides, viz., carbon monoxide and carbon dioxide. The bonding in carbon monoxide may be represented as, three electron pairs shared between the two atoms. The three electron pairs consist of one sp hybridized σ bond and two π bonds.



The structure of carbon dioxide on the other hand is linear $\text{O}=\text{C}=\text{O}$. There are two σ bonds and two π bonds in the molecule CO_2 . The carbon atom uses sp hybrid orbitals to form σ bonds with oxygen atoms. The remaining two $2p$ orbitals of carbon overlap with $2p$ orbitals one each from the two O atoms to form the π bonds



Notes

Silicon also forms two oxides : SiO and SiO₂. Not much is known about silicon monoxide as its existence is only known at high temperatures. Silica (SiO₂) is widely found as sand and quartz.

Properties

Carbon monoxide is a neutral oxide. It is a colourless, odourless and a poisonous gas and burns with a blue flame. It is toxic because it forms a complex with the haemoglobin in the blood which prevents the haemoglobin from carrying oxygen around the body. This leads to oxygen deficiency resulting in unconsciousness or death. Carbon monoxide is an important industrial fuel and is also a strong reducing agent.

Carbon dioxide is an acidic oxide. It is a colourless and odourless gas and can be liquified under pressure at low temperature. Solid carbon dioxide is called dry ice.

SiO₂ is an acidic oxide and is unreactive in all its forms. It shows very limited reactions. It dissolves slowly in aqueous alkalis and more rapidly in fused alkalis or fused carbonates forming silicates. Silica also reacts with fluorine and HF to form silicon tetrafluoride

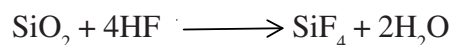
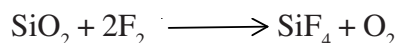
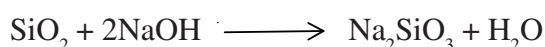

Uses of oxides of carbon

Carbon monoxide

- (i) It is used as a reducing agent in metallurgical processes to reduce metal oxides. For example, in the blast furnace, it is used to reduce iron oxide to iron.

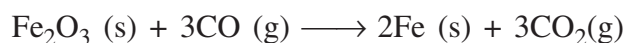

- (ii) In the presence of a catalyst, it can combine with hydrogen to give methanol (CH₃OH).
- (iii) It forms carbonyl compounds. The nickel carbonyl Ni(CO)₄ is involved in the refinement of nickel.
- (iv) It is used as a fuel.
- (v) It is used in the synthesis of several organic compounds.

The main uses of carbon dioxide are as follows:

- (i) Solid carbon dioxide also called *dry ice* is used as a refrigerant because when it is cooled at atmospheric pressure, it condenses into a solid rather than as a liquid. This solid sublime at -78°C



Notes

- (ii) It is used in the production of *carbonated drinks*.
- (iii) It is used in the production of washing soda ($\text{Na}_2\text{CO}_3 \cdot 10\text{H}_2\text{O}$) and baking soda (NaHCO_3).

SiO_2 is a high melting solid and it exists in twelve different forms, each of which, has different structure. The main forms are quartz and cristobalite, each of which has a different structure at different temperatures. In all these forms silicon is tetrahedrally surrounded by four oxygen atoms and each oxygen is attached to two silicon atoms. The sp^3 orbitals of Si overlap with 2p orbitals of O atoms. Each corner of tetrahedron is shared by other tetrahedra. This gives an infinite structure – a macromolecule.

19.4.3 Halides of Carbon and Silicon

Carbon and silicon form tetrahalides like CCl_4 and SiCl_4 , respectively. In the tetrahalides of these elements there are four covalent bonds, with a tetrahedral arrangement; the central atom is sp^3 hybridized. Carbon tetrachloride can be rightly called as tetrachloromethane and silicon tetrachloride as tetrachlorosilane.

- Carbon tetrachloride is prepared by the action of chlorine on carbon disulphide in the presence of a catalyst (usually MnCl_2)

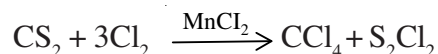

Silicon tetrachloride, SiCl_4 , is formed by heating amorphous silicon in a current of dry chlorine.

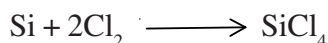

It can also be obtained by passing dry chlorine over an intimate mixture of silica and carbon strongly heated in a crucible. Thus

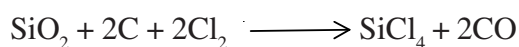

Carbon tetrachloride is not hydrolysed by water whereas silicon tetrachloride is readily hydrolysed.

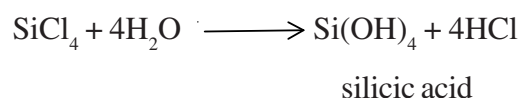

The difference in the behaviour of CCl_4 and SiCl_4 towards water can be explained as follows.

A lone pair of electrons from the O atom of H_2O molecule is donated to the empty 3d orbital on Si. Subsequently one of the hydrogen atoms of water molecule combines with a chlorine atom of SiCl_4 . This process goes on till all the chlorine atoms are replaced by $-\text{OH}$ groups.



Notes

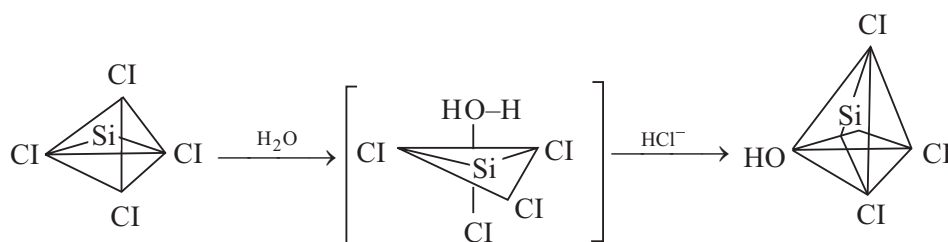

Since, there is no d -orbital in carbon in CCl_4 does not hydrolyse.

Silicon forms complex ion like SiF_6^{2-} but carbon does not form similar ions like CF_6^{2-} . It is because unlike carbon there are empty $3d$ orbitals in silicon. The availability of d orbitals is responsible for the ability of silicon and not carbon to form complex ion SiF_6^{2-} .

19.4.4 Silicon Carbide, SiC

Silicon carbide (SiC) is commonly known as *carborundum*. It is extremely hard and chemically a very stable material. It is made by heating silica with excess of carbon in an electric furnace

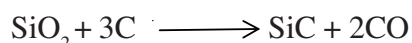

In silicon carbide, there are three dimensional arrays of Si and C atoms, each atom of Si or C is tetrahedrally surrounded by four of the other type. Thus, this structure is very much similar to that of diamond. Silicon carbide or carborundum is widely used as an abrasive.

19.4.5 Silicones

These compounds are polymeric, the polymer chain containing alternately linked silicon and oxygen atoms. Alkyl or aryl groups, e.g. CH_3 or C_6H_5 , are attached to the polymer backbone by means of covalent bonds to the silicon atoms. A typical silicone has the formula:

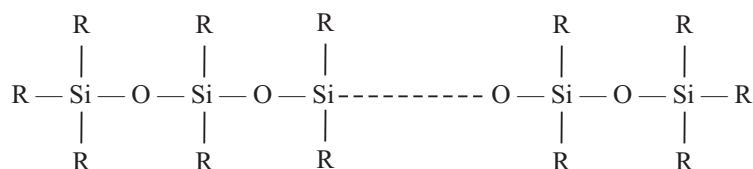

where R is an alkyl or aryl group.

Silicones are obtained by reacting a chloroalkane or a chlorobenzene with silicon in the presence of a copper catalyst and at a temperature of about 300°C . A mixture of alkyl or aryl chlorosilanes results:



Notes



After fractional distillation, the silane derivatives are hydrolysed and the 'hydroxides' immediately condense by intermolecular elimination of water. The final product depends upon the number of hydroxyl groups originally bonded to the silicon atom:

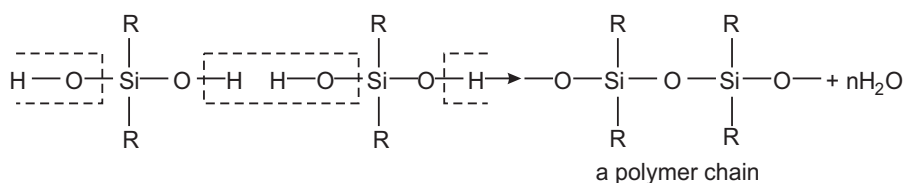
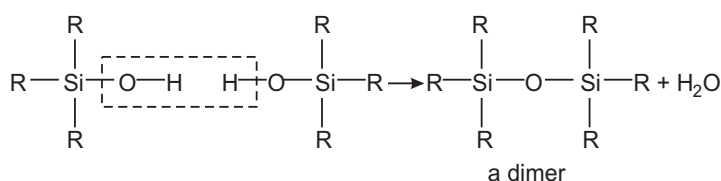
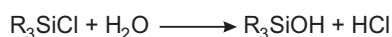

The polymer chain depicted above is terminated by incorporating a small quantity of the monochlorosilane derivative into the hydrolysis mixture.

Hydrolysis of the trichlorosilane derivative gives a two-dimensional structure. By blending a mixture of chlorosilanes before hydrolysis, it is possible to produce polymers of varying chain length, R_3SiOH acting as a chain stopper and $RSi(OH)_3$ as a cross-linking agent.

The hydrocarbon layer along the silicon-oxygen chain makes silicones water-repellent. Silicone fluids are thermally stable and their viscosity alters very little with temperature, and silicone rubbers retain their elasticity at much lower temperatures than ordinary rubber.

19.4.6 Silicates

The tendency of silicon to form single covalent bonds with oxygen atoms has been observed in the structures of silica and polysilicic acid. These structures and also those of a bewildering variety of silicates are now readily understood in terms of the linking together of tetrahedral SiO_4 units. Pauling considers the silicon-oxygen bond to be about 50 per cent ionic, and it is sometimes convenient to discuss the structures of silicates in terms of Si^{4+} ions tetrahedrally surrounded by four much larger oxygen atoms. Examples of some typical silicates are given below (Fig. 19.7).

Silicates containing discrete SiO_4^{4-} anions

Orthosilicates contain the simple SiO_4^{4-} ion, one example being beryllium



Notes

orthosilicate, $(\text{Be}^{2+})_2\text{SiO}_4^{4-}$. As mentioned above, the SiO_4^{4-} group is tetrahedral, as would be expected.

19.4.6.1 Silicates containing $\text{Si}_2\text{O}_7^{6-}$ anions (one oxygen atom shared)

When one oxygen atom is shared between two tetrahedra, the pyrosilicate anion, $\text{Si}_2\text{O}_7^{6-}$ is the result. A typical pyrosilicate is $(\text{Sc}^{3+})_2\text{Si}_2\text{O}_7^{6-}$.

19.4.6.2 Silicates containing extended anions (two oxygen atoms shared and (d))

When each tetrahedron shares two oxygen atoms, it is possible to have closed ring anions such as $\text{Si}_3\text{O}_9^{6-}$. Another possibility is the formation of infinite chains, the formula of these anions approximating to $(\text{SiO}_3)_n^{2n-}$. Examples of silicates containing these anions are $\text{Be}^{2+}\text{Ti}^4\text{Si}_3\text{O}_9^{6-}$ and $\text{Ca}^{2+}\text{Mg}^{2+}(\text{SiO}_3^{2-})_2$.

When each tetrahedron shares three oxygen atoms, silicates in the form of extended sheets result. The empirical formula of these polysilicate anions is SiO_2^{1-} or $\text{Si}_4\text{O}_{10}^{4-}$. Anions of this type are found in micas and clays and account for their ready cleavage into thin slices.

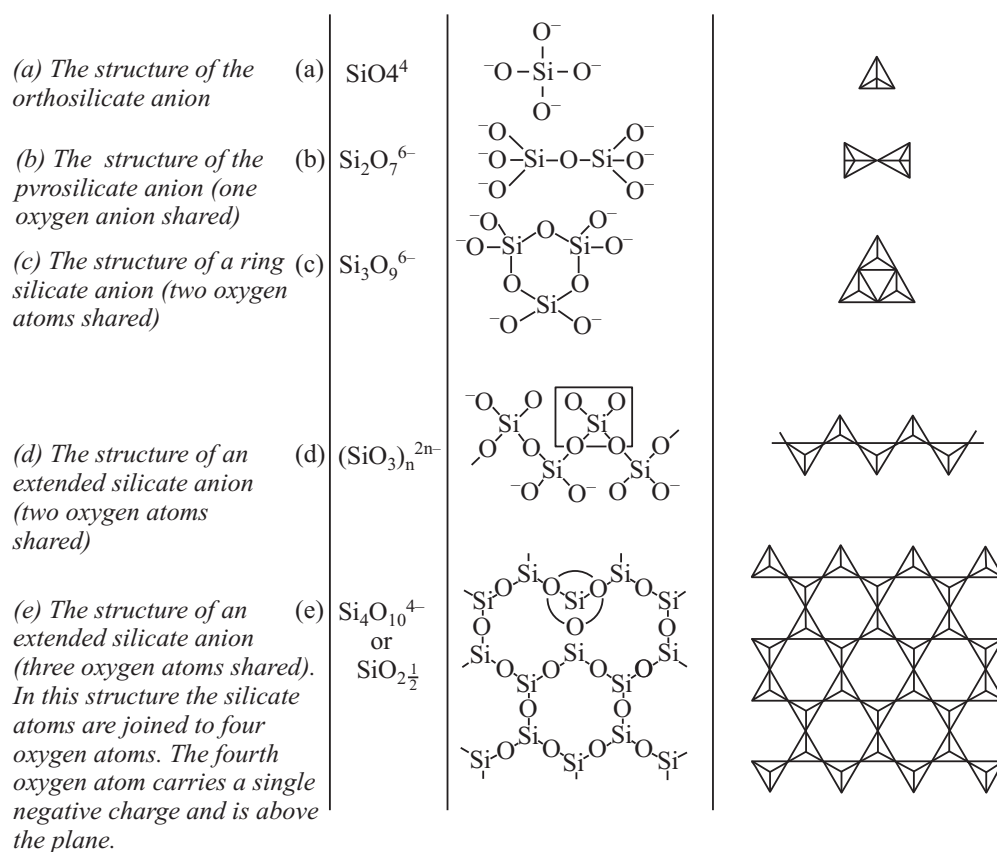

Fig. 19.7: Structure of Silicates



Notes

19.4.6.3 Zeolites

Zeolites have a much more open structure than the feldspars. The anion skeleton is penetrated by channels, giving a honeycomb-like structures These channels are large enough to allow them to exchange certain ions. They can also absorb or lose water and other small molecules without the structure breaking down. Zeolites are often used as ion-exchange materials, and as molecular sieves. Natrolite $\text{Na}_2[\text{Al}_2\text{Si}_3\text{O}_{10}]\cdot 2\text{H}_2\text{O}$ is a natural ion exchanger. Permutit water softeners use sodium zeolites. Zeolites take Ca^{2+} ions from hard water and replace them by Na^+ , thereby softening the water. The sodium zeolite (natrolite) gradually becomes a calcium zeolite, and eventually has to be regenerated by treatment with a strong solution of NaCl , when the reverse process takes place. In addition to naturally occurring minerals, many synthetic zeolites have been made. Zeolites also act as molecular sieves by absorbing molecules which are small enough to enter the cavities, but not those which are too big to enter. They can absorb water, CO_2 , NH_3 and EtOH , and they are useful for separating straight chain hydrocarbons from branched chain compounds. Some other zeolites are healandite $\text{Ca}[\text{Al}_2\text{Si}_7\text{O}_{18}]\cdot 6\text{H}_2\text{O}$, chabazite $\text{Ca}[\text{Al}_2\text{Si}_4\text{O}_{12}]\cdot 6\text{H}_2\text{O}$, and analcite $\text{Na}[\text{AlSi}_2\text{O}_6]\cdot \text{H}_2\text{O}$. Molecular sieves can be made with pores of appropriate size to remove small molecules selectively.



Notes



INTEXT QUESTIONS 19.2

1. Write two properties of diamond which are not exhibited by graphite.
2. What is the state of hybridization of carbon in (i) diamond (ii) graphite?
3. What is the nature of bond in carborundum?
4. Write the state of hybridization of carbon in CCl_4
5. Which one is affected by water and why; CCl_4 or SiCl_4 ?
6. Which is an acidic oxide, CO or CO_2 ?
7. What happens when SiO_2 is attacked by F_2 ?

19.5 SOME GENERAL CHARACTERISTICS OF ELEMENTS OF GROUP 15

This group consists of N, P, As, Sb and Bi.

Group 15 elements can complete the octet in chemical combination by gaining three electrons to form the 3-valent anion, by forming three covalent bonds, or by losing five electrons; the last possibility is ruled out on energetic grounds. Only nitrogen (and possibly phosphorus to a slight extent) forms the 3-valent ion and reactive metals are required for it to be possible; the N^{3-} ion is present

in ionic nitrides, e.g. $(\text{Li}^+)_3\text{N}^{3-}$ and $(\text{Ca}^{2+})_3(\text{N}^{3-})_2$. The majority of compounds formed by this group of elements are covalent.

Antimony and bismuth can form the 3-valent cation X^{3+} (the inert-pair effect), the Sb^{3+} ion being present in $(\text{Sb}^{3+})_2(\text{SO}_4^{2-})_3$ and the Bi^{3+} ion in $\text{Bi}^{3+}(\text{F}^-)_3$ and $\text{Bi}^{3+}(\text{NO}_3^-)_3 \cdot 5\text{H}_2\text{O}$.

Because phosphorus, arsenic, antimony and bismuth have vacant d orbitals they are able to form 5-covalent compounds which are not possible for nitrogen, e.g. in the formation of PCl_5 , one of the $3p$ electrons of the phosphorus atom is promoted to the $3d$ level, giving five unpaired electrons for valency purposes.

Nitrogen and phosphorus are non-metallic; metallic properties first become apparent with arsenic and become progressively more important for antimony and bismuth. Of these elements only nitrogen is able to multiple bond with itself, the triple bond being present in the nitrogen molecule, $\text{N}\equiv\text{N}$.

Table 19.4: Physical properties of Group 15 elements

	Atomic Number	Electronic Configuration	Atomic Radius/nm	Ionic Radius/nm M^{3+}	M.P. /°C	B.P. /°C
N	7	2.5 $1s^2 2s^2 2p^3$	0.074		-210	-196
P	15	2.8.5 $\dots 2s^2 2p^6 3s^2 3p^3$	0.110		44.1 (white)	280 (white)
As	33	2.8.18.5 $\dots 3s^2 3p^6 3d^{10} 4s^2 4p^3$	0.121	0.069		613 (sublimation)
Sb	51	2.8.18.18.5 $\dots 4s^2 4p^6 4d^{10} 5s^2 5p^3$	0.141	0.090	630	1380
Bi	83	2.8.18.18.8.5 $\dots 5s^2 5p^6 5d^{10} 6s^2 6p^3$	0.152	0.120	271	1560

Occurrence

Nitrogen occurs as an inert diatomic gas, 78 percent by volume in the atmosphere. Inorganic nitrogen compounds are usually soluble and are rarely found in nature except Chile saltpetre. Both nitrogen and phosphorus are essential constituents of all plant and animal tissue: nitrogen is present in proteins; and phosphorus is present as calcium phosphate in bones and teeth.

Dinitrogen

Preparation of dinitrogen

Nitrogen can be obtained :

(A) From air by the removal of oxygen etc., by physical or chemical means.



Notes

(B) By the decomposition of nitrogen compounds.

(A) *From air* : (a) The gas left after the removal of oxygen and carbon dioxide from air is almost nitrogen. Air is passed through two wash bottles one containing a solution of sodium hydroxide and the other sulphuric acid which remove carbon dioxide and moisture respectively. The dry air is now passed over heated iron or copper to remove oxygen.

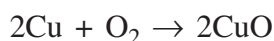

Nitrogen so collected in gas jars or holders contains about 1 per cent of noble gases.

(b) *By fractional evaporation of liquid air* : Nitrogen for industrial requirements is manufactured by this method. The boiling point of liquid nitrogen is -195.8°C , and of liquid oxygen is -183°C . Thus, the difference of 12.8°C in their boiling points, is sufficient to allow their separation from liquid air. T

(B) *From nitrogen compounds* : Nitrogen prepared from chemical compounds is usually called “*chemical nitrogen*”. It is conveniently prepared in the laboratory by the following methods :

(i) When a solution of ammonium nitrite is heated in a flask, nitrogen is obtained.

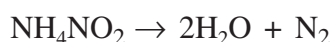

(ii) *By the oxidation of ammonia* : When chlorine is passed into an excess of concentrated ammonia solution, nitrogen is evolved which is bubbled through water to remove ammonia and ammonium chloride.

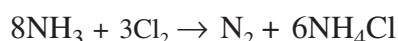
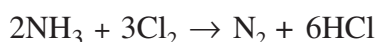

If ammonia is not present in excess or the action is prolonged, nitrogen trichloride is also formed which is highly explosive.

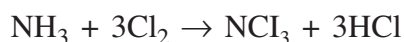

(iii) Very pure nitrogen is evolved by heating sodium or barium azide in vacuum.

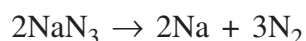
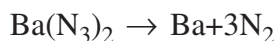

Properties

Physical: Nitrogen is a colourless, odourless and tasteless diatomic gas. Its specific gravity in the gaseous state is 0.96737, in the liquid state 0.804, and in the solid state 1.0265. It is slightly soluble in water, 100 volumes of water at 20°C dissolve only 1.64 volumes of gas. At -195.5°C it is condensed to a



Notes

colourless liquid which freezes to a white snow-like mass at -210°C . The gas is non-poisonous, but simply dilutes the oxygen of the air. Animals die in nitrogen for want of oxygen only. The gas is neither combustible nor a supporter of combustion,

It has been noted that at 3500°C about 5 per cent of nitrogen is dissociated into atoms.

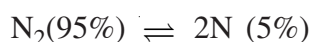

Chemical : It is inert at room temperature because a large amount of energy is required to break $\text{N} \equiv \text{N}$ bond. However, the compounds of nitrogen show great chemical activity.

- (i) When nitrogen is passed over heated metals like lithium, calcium, magnesium and aluminium, it forms nitrides.

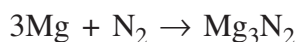
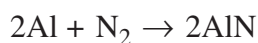

These nitrides are readily decomposed by water.

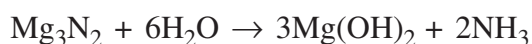

- (ii) At 200 atmospheres and in presence of a catalyst, finely divided iron and molybdenum as promotor at 450°C - 500°C , nitrogen combines with hydrogen. This reaction is utilized for the manufacture of ammonia by the Haber process.



- (iii) It combines with carbides to form cyanamides which react with superheated steam to evolve ammonia.

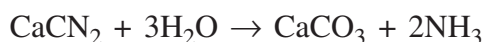
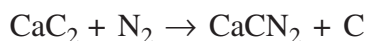

- (iv) In presence of lightning discharge or an electric spark, nitrogen combines with oxygen to form nitric oxide.



This reaction is utilized for the manufacture of nitric acid.

Uses

- (i) Nitrogen is used on a large scale for the manufacture of ammonia, nitric acid and other important nitrogen compounds.
- (ii) It is used for filling electric bulbs,
- (iii) In the manufacture of high temperature thermometers.
- (iv) It is also used for providing an inert atmosphere in metallurgy and other industrial processes.



Notes

- (v) It is the basis of two important activities of man (a) agriculture and (b) explosive.
- (vi) It is used as a source of cold when liquefied.

Structure of the Oxides of Nitrogen

Dinitrogen Oxide, N₂O

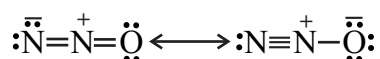

Nitrogen Oxide, NO

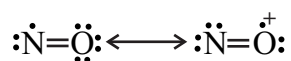

Dinitrogen trioxide, N₂O₃

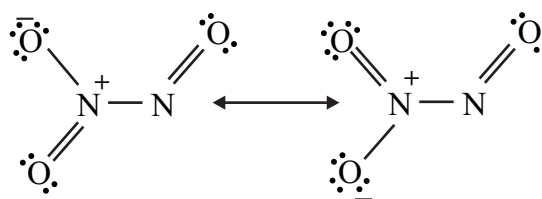

Nitrogen dioxide, NO₂

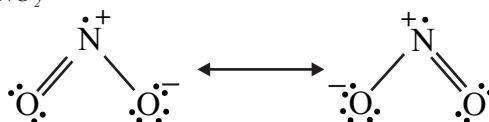

Dimer of NO₂ (N₂O₄)

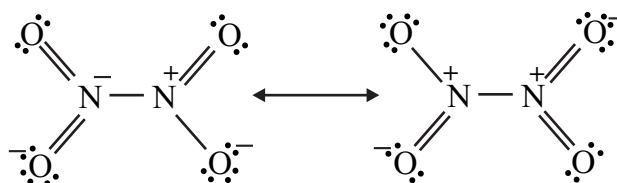

Dinitrogen Pentaoxide

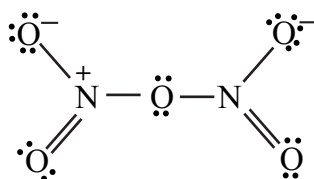

Notes

19.6 NITROGEN AND PHOSPHORUS

Nitrogen and phosphorus belong to Group 15 of the periodic table. They form a number of industrially important compounds like ammonia, nitric acid and fertilizers. Let us study about them.

19.6.1 Ammonia

Ammonia is prepared in the laboratory by heating an ammonium salt with a base:

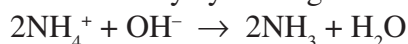

or



It may also be prepared by treating a nitride with water.

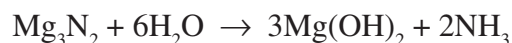

It is manufactured industrially by passing nitrogen and hydrogen over an iron catalyst at 750 K and under a pressure of about 200 atmospheres (Haber's process).



In the actual process the hydrogen required is obtained from water gas and the nitrogen from the fractional distillation of liquid air. The mixture of nitrogen and hydrogen (1 : 3 by volume) is compressed to 200-300 atm and then passed into the catalytic tubes packed with the catalyst. The catalyst is made by fusing Fe_3O_4 with KOH and Al_2O_3 . The temperature of the catalytic tubes is maintained at 673–773K by heating them electrically. The issuing gas containing about 10 per cent ammonia is cooled and the liquid ammonia condenses. The unconverted mixture of hydrogen and nitrogen is returned to the inlet and passed again over the catalyst. A typical plant might be arranged as shown in Fig.19.7

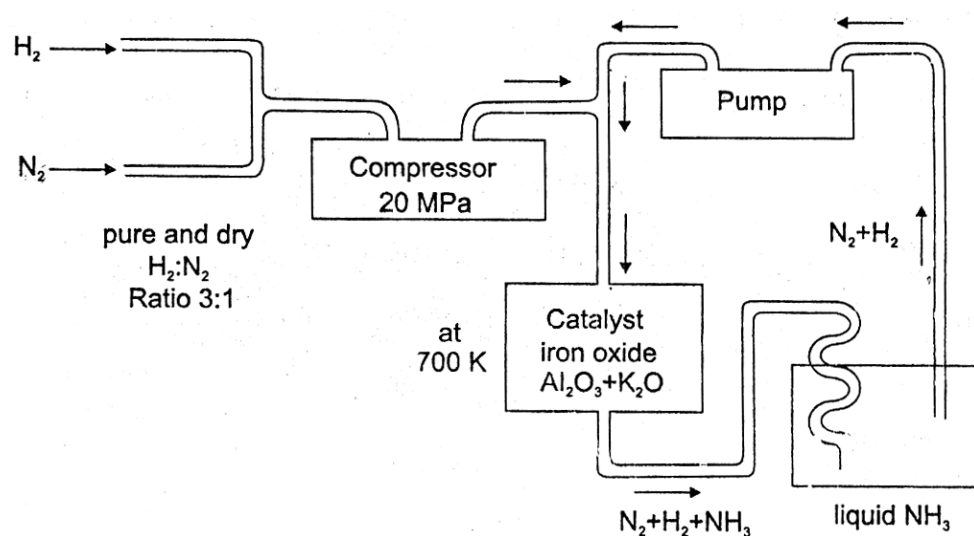

Fig. 19.7 : The Haber process for the manufacture of ammonia



Notes

Properties

Ammonia is a colourless and pungent smelling gas. It is readily liquified at a pressure of about nine atmospheres at ordinary temperatures. The liquid boils at -239.6K and freezes at -96K . Liquid ammonia resembles water in being highly associated because of its polar nature and strong hydrogen bonding.

Ammonia is extremely soluble in water. The hydrated ammonia molecule, $\text{NH}_3 \cdot \text{H}_2\text{O}$, is loosely called ammonium hydroxide, NH_4OH , which is a weak base, the ionization reaction being

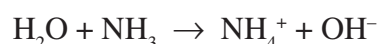

The undissociated molecule, NH_4OH , is essentially a non-existent entity. It can only exist as NH_4^+ and OH^- ions.

Chemical reactions

- (i) **Action of heat:** When heated above 500°C it begins to decompose into its elements. The decomposition is accelerated by metallic catalysts

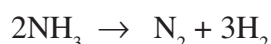

- (ii) **With oxygen :** Ammonia does not burn in air but freely burns in pure oxygen with a yellowish flame giving nitrogen and steam

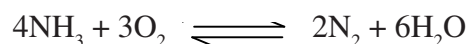

In the presence of a catalyst, e.g. hot platinum, ammonia burns in air to give nitric oxide

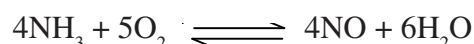

- (iii) **As a reducing agent.** If ammonia is passed over those heated metallic oxides which are reducible by hydrogen, e.g. CuO , PbO , etc, it is oxidised to nitrogen and water :

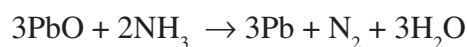

- (iv) **With acids.** It is easily absorbed by acids to form ammonium salts, e.g.:

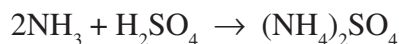

The reaction can occur even if the acid is a gas, e.g.:



- (v) **With chlorine.** Ammonia reacts with chlorine, the products varying according to conditions :



Notes

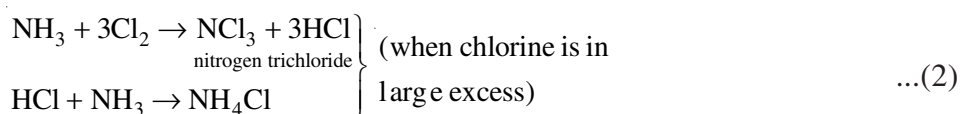

(vi) **With metal salts.** With some metal salts, aqueous ammonia reacts to form metal hydroxides which are precipitated.

For example, ammonia solution precipitates copper(II) hydroxide when treated with a copper salt,

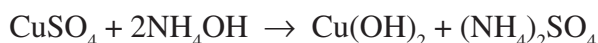

In excess of ammonia, the precipitate of Cu(OH)_2 dissolves to form tetraammine complex

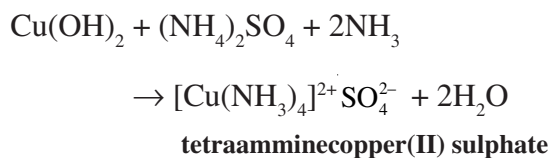

Similar complexes are formed with many metallic salts and complex ions such as $[\text{Ag}(\text{NH}_3)_2]^+$, $[\text{Co}(\text{NH}_3)_6]^{3+}$, $[\text{Cr}(\text{NH}_3)_6]^{3+}$ and $[\text{Ni}(\text{NH}_3)_6]^{2+}$ are well known.

Uses :

Ammonia is used for a number of purposes, some important uses are :

- (i) In the manufacture of ammonium sulphate for use as a fertilizer.
- (ii) In the manufacture of nitric acid (Ostwald process)
- (iii) In the manufacture of sodium carbonate by Solvay process.
- (iv) Liquid ammonia is used in refrigerators.
- (v) Ammonia solution is used as a domestic cleaner : as a grease remover and in laundry.

Structure : Ammonia molecule is trigonal pyramid with the nitrogen at the apex. The nitrogen atom is sp^3 hybridized in which a lone pair of electrons occupies one of the tetrahedral positions. The angle $\text{H}\hat{\text{N}}\text{H}$ becomes 107° instead of 109° (in CH_4) due to lone pair-bond pair repulsion (Fig. 19.8).

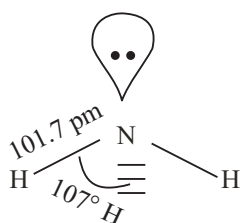

Fig. 19.8 : Structure of ammonia



Notes

19.6.2 Oxoacids of Nitrogen

There are several oxoacids of nitrogen such as nitrous acid, HNO_2 , hyponitrous acid, $\text{H}_2\text{N}_2\text{O}_2$ and nitric acid, HNO_3 . Of these nitric acid is the most important and will be considered here in detail.

Nitric Acid, HNO_3

Preparation

In the laboratory, nitric acid can be prepared by heating NaNO_3 or KNO_3 with concentrated H_2SO_4 in a glass retort and condensing the vapours coming out of the retort.

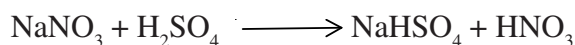

In industry it is manufactured by the catalytic oxidation of ammonia which involves the following reactions (Ostwald process) :

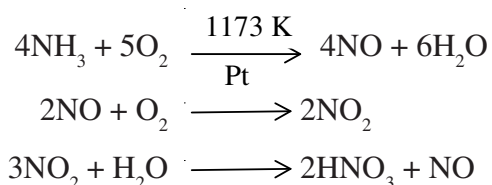

The aqueous nitric acid can be concentrated by distillation followed by dehydration with conc. H_2SO_4 .

Properties

Physical : It is a colourless liquid of density 1.50 g cm^{-3} at 248 K. The acid is freely miscible with water forming a constant boiling mixture containing 98% of acid, b.p.393K.

Chemical : (a) In aqueous solution, nitric acid is a strong acid and dissociates to give hydronium and nitrate ions.

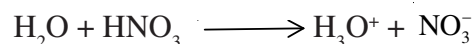

(b) It is neutralised by appropriate alkalies to yield nitrates.

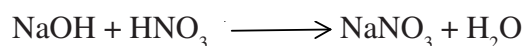

(c) On heating it gives NO_2



(d) It is a good oxidizing agent and oxidizes non metals, metals and organic compounds, some examples of which are given below :

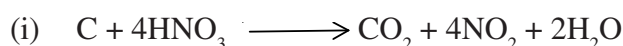

Notes

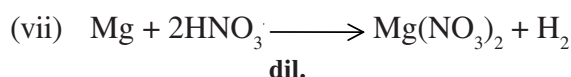
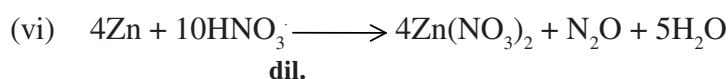
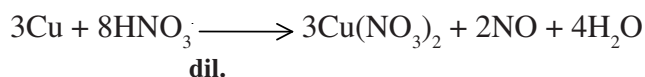
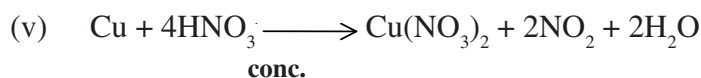
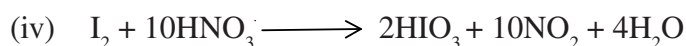
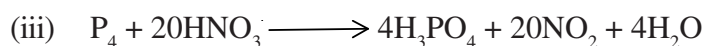
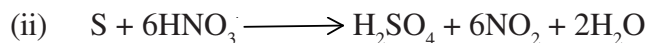

(viii) Aluminium loses its normal reactivity i.e. becomes passive after being dipped in conc. HNO_3 . This is due to the formation of a thin protective layer of aluminium oxide on its surface which prevents further action.

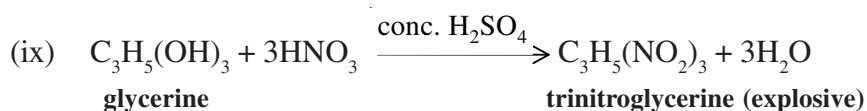

Structure : In the gaseous state HNO_3 exists as a planar molecule with the structure: (Fig. 19.9):

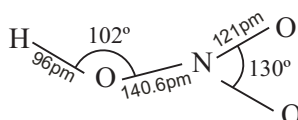

Fig. 19.9 : Structure of nitric acid molecule

Uses : Nitric acid is used in the manufacture of nitrates which are used as fertilizers, and explosives, trinitrolycerine and trinitrotoluene (TNT)

- It is used as an oxidizing agent in laboratory, e.g. Fe(II) gets oxidized to Fe(III)
- Conc. HNO_3 is a constituent of aqua regia ($HNO_3 : HCl = 1 : 3$)
- HNO_3 (100%) is a constituent of rocket propellant.

19.6.3 Allotropic forms of Phosphorus

The allotropy of phosphorus is rather complex but, essentially, there are three allotropic forms known as white, red and black phosphorus.

White phosphorus is formed as a soft, waxy solid whenever phosphorus vapour is condensed; structurally it contains tetrahedral P_4 units held together by van



Notes

der Waals' forces. Since the P–P–P bond angles are 60° in each of these P_4 units there is a considerable amount of strain, and this makes itself felt in the high chemical reactivity of this allotrope.

White phosphorus very slowly changes into the red variety in the course of many years; this change can be accelerated by raising the temperature, and commercially this allotrope is made from white phosphorus by heating in the absence of air to 270°C for several days. Its structure is not known with certainty but it is certainly macromolecular; it is denser than white phosphorus.

The third allotrope, black phosphorus, can be obtained by subjecting white phosphorus to high pressures at 200°C in the absence of air. It too is macromolecular, with each phosphorus atom surrounded by three more atoms. It is an electrical conductor resembling graphite in this respect and also in its flakiness. Its density is higher than that of red phosphorus.

Only white and red phosphorus are normally encountered in the laboratory.

19.6.4 Phosphorus Halides

Phosphorus trichloride, PCl_3

The trichloride, is obtained by passing chlorine over white phosphorus. The phosphorus burns with a pale green flame and phosphorus trichloride distils and is condensed as a colourless liquid. Since it is attacked by air and water, it is necessary to displace the air from the apparatus with a stream of carbon dioxide and to include a soda-lime drying tube.

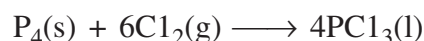

Phosphorus trichloride is readily hydrolysed by water to phosphonic acid, H_3PO_3 , and hydrogen chloride:

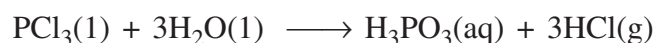

It is thought that the reaction takes place in stages, with the formation of complexes in which the oxygen atom of a water molecule is attached to the phosphorus atom (expansion of the octet can occur since the phosphorus atom has d orbitals available):

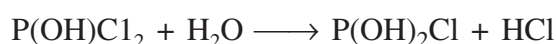
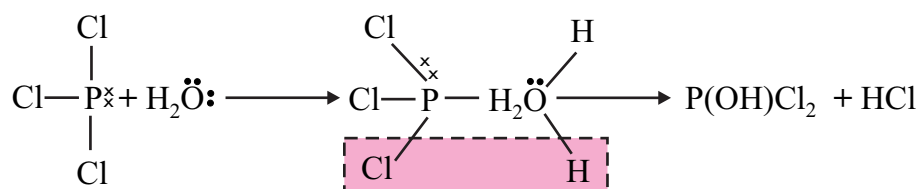

Phosphorus trichloride reacts with many compounds containing the $-\text{OH}$ group, and it is used in organic chemistry for the preparation of acid chlorides and alkyl chlorides, e.g.



Notes

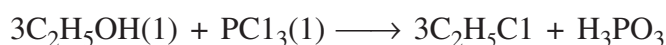
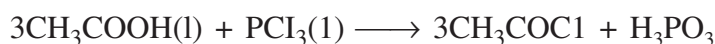

It readily combines with oxygen and chlorine (reversibly), the phosphorus atom increasing its covalency from three to five:

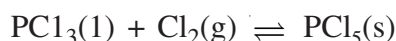
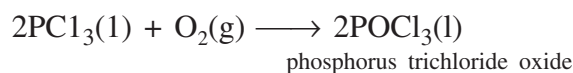

Phosphorous pentachloride, PCl_5

Phosphorus pentachloride is prepared by passing chlorine through a flask into which phosphorus trichloride is dripping. Since it dissociates into the trichloride and chlorine very readily, the experiment is conducted in an ice-cooled apparatus.

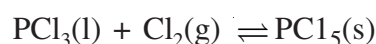

Like the trichloride it is attacked by compounds containing the hydroxyl group, e.g.

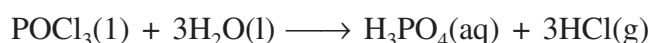
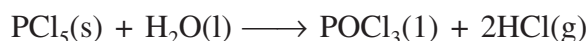

In the vapour state the phosphorus pentachloride molecule has a trigonal bipyramidal structure (Fig. 18.10(a)); in the solid state it is ionic, having the structure $(\text{PCl}_4^+)(\text{PCl}_6^-)$ (Fig. 18.10(b)).

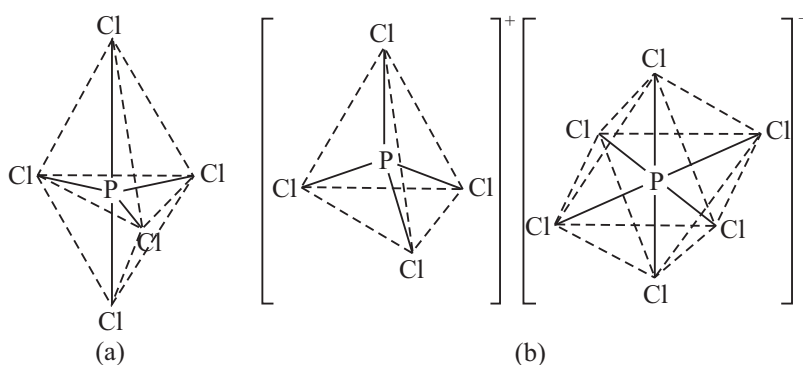

Table 19.10: The acids of phosphorus and their properties.

Acid	Nature	Preparation		Anion
H_3PO_2 or $\text{H}_2\text{P}(\text{OH})\text{O}$ hypophosphorous	crystalline white solid	white P_4 + alkali $\text{H}_2\text{PO}_2^- + \text{H}_2$	H_2PO_2^- hypophosphite	strongly reducing monobasic $\text{p}K = 2$
H_3PO_3 or $\text{HPO}(\text{OH})_2$ orthophosphorous	deliquescent colourless solid	P_2O_3 or PCl_3 + H_2O	H_2PO_3^- , HPO_3^{2-} phosphite	reducing, but slow dibasic $\text{p}K_1 = 2$ $\text{p}K_2 = 6$



Notes

p-block Elements and their Compounds – I

H_3PO_4	white solid	$\text{P}_2\text{O}_5 + \text{H}_2\text{O}$	H_2PO_4^- , HPO_4^{2-}	not oxidizing, tribasic
Orthophosphoric			PO_4^{3-} phosphate	
$\text{H}_2\text{P}_2\text{O}_4$	colourless	heat phosphates	$\text{P}_2\text{O}_7^{4-}$	tetrabasic $\text{p}K_{-1} = 2$
pyrophosphoric	solid linear and cyclic anions	or phosphoric acid heating phosphates	pyrophosphate $[\text{PO}_3(\text{PO}_3)_n\text{OPO}_3]^{(4+n)-}$ $[\text{PO}_3]_n^-$ polyphosphate	

MODULE - 6

Chemistry of Elements



Notes

Structure of Oxyacids of Phosphorous

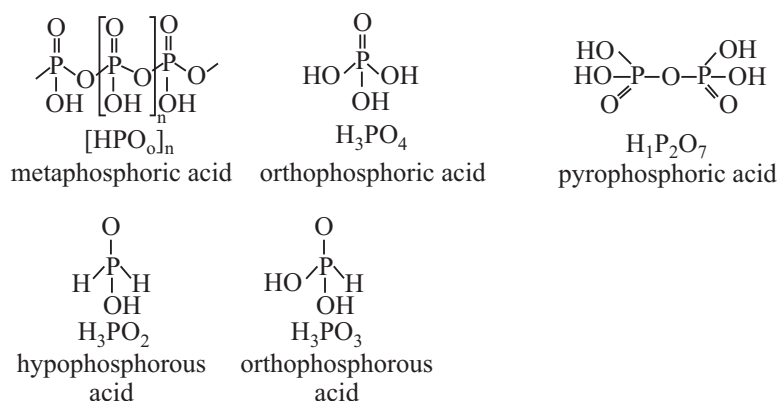

INTEXT QUESTIONS 19.3

- Does 'NH₄OH' exist as a molecule?
- What is the bond angle in NH₃ molecule?
- What is the state of hybridization of N in NH₃?
- Draw the structure of pyrophosphoric acid.
- What happen when PCl₃ is treated with water.



WHAT YOU HAVE LEARNT

- General Characteristic of Group 13, 14, & 15.
- Method of preparation of boric acid. The acidic nature and structure of boric acid.
- Method of preparation and uses of borax.

- Methods of preparation and uses of boron trifluoride and diborane.
- The Lewis character and use of boron trifluoride.
- Preparation of aluminium trichloride and its structure
- Method of preparation of alums and uses
- The comparison of diamond and graphite.
- The structure and properties of carbon monoxide, carbon dioxide and silicon dioxide and their uses.
- Comparison of the hydrolytic behaviour of carbon tetrachloride and silicon tetrachloride.
- Preparation and uses of silicon carbide (carborundum)
- Preparation and uses of silicones.
- Preparation and structure of silicates and zeolites.
- Preparation, properties and uses of nitrogen.
- Structure of oxides of nitrogen.
- The methods of preparation, properties and uses of ammonia and nitric acid.
- Structure of the oxides and oxoacids of nitrogen Halides of phosphorus Allotropic forms of phosphorus oxyacids of phosphorus.



TERMINAL QUESTIONS

1. Why is boric acid not a protonic acid?
2. Discuss the structure of boric acid.
3. Draw the Lewis structure of CO and CO₂ molecules.
4. Why does BF₃ act as a Lewis acid?
5. What is catenation ? Why does carbon show catenation but silicon does not?
6. Compare the structure of CO₂ and SiO₂.
7. Describe briefly the Haber process for the manufacture of ammonia.
8. Why is graphite a conductor of electricity but diamond is not?
9. Explain different types of silicones.
10. Explain ortho and pro silicates.



Notes



ANSWERS TO INTEXT QUESTIONS

19.1

- (i) $B(OH)_3$ (ii) $Na_2B_4O_7 \cdot 10H_2O$
- $4BCl_3 + 3LiAlH_4 \rightarrow 2B_2H_6 + 3AlCl_3 + 3LiCl$
- $NM(SO_4)_2 \cdot 12H_2O$

Where N = monovalent large cation like K^+ or NH_4^+ and M = trivalent cation like Al^{3+} , Fe^{3+} , Cr^{3+}

- Al_2Cl_6
- (i) as a flux, for glazing pottery and tiles : in the manufacture of optical and borosilicate glasses.
(ii) as an antiseptic, as a food preservative, for making enamels
(iii) as a catalyst in Friedel-Crafts reaction.
- Monoprotonic
- Due to the formation of oxide layer

19.2

- Hardness and conducting nature. Diamond : hard, non conducting; graphite: soft, conducting.
- sp^3 in diamond and sp^2 in graphite.
- Covalent
- sp^3
- $SiCl_4$, as silicon can accept electron pair in its d-orbitals from water molecule.
- CO_2
- $SiO_2 + 2F_2 \rightarrow SiF_4 + O_2$

19.3

- No. Nitrogen cannot increase its covalency beyond 4.
- 107^0 .
- sp^3

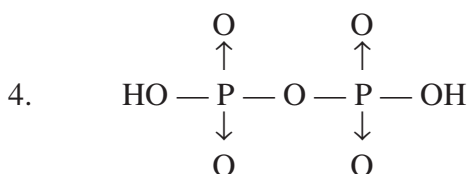

- $PCl_3 + 3H_2O \longrightarrow H_3PO_3 + 3HCl$



Notes