

MODULE - 5

Electricity and
Magnetism



Notes



19

ELECTROMAGNETIC INDUCTION AND ALTERNATING CURRENT

Electricity is the most convenient form of energy available to us. It lights our houses, runs trains, operates communication devices and makes our lives comfortable. The list of electrical appliances that we use in our homes is very long. Have you ever thought as to how is electricity produced?

Hydro-electricity is produced by a generator which is run by a turbine using the energy of water. In a coal, gas or nuclear fuel power station, the turbine uses steam to run the generator. Electricity reaches our homes through cables from the town substation. Have you ever visited an electric sub-station? What are the big machines installed there? These machines are called transformers. Generators and transformers are the devices, which basically make electricity easily available to us. These devices are based on the principle of electromagnetic induction.

In this lesson you will study electromagnetic induction, laws governing it and the devices based on it. You will also study the construction and working of electric generators, transformers and their role in providing electric power to us. A brief idea of eddy current and its application will also be undertaken in this chapter.



OBJECTIVES

After studying this lesson, you should be able to :

- *explain the phenomenon of electromagnetic induction with simple experiments;*
- *explain Faraday's and Lenz's laws of electromagnetic induction;*
- *explain eddy currents and its applicaitons;*



- describe the phenomena of self-induction and mutual induction;
- describe the working of ac and dc generators;
- derive relationship between voltage and current in ac circuits containing a (i) resistor, (ii) inductor, and or (iii) capacitor;
- analyse series LCR circuits; and
- explain the working of transformers and ways to improve their efficiency.

19.1 ELECTROMAGNETIC INDUCTION

In the previous lesson you have learnt that a steady current in a wire produces a steady magnetic field. Faraday initially (and mistakenly) thought that a steady magnetic field could produce electric current. Some of his investigations on magnetically induced currents used an arrangement similar to the one shown in Fig.19.1. A current in the coil on the left produces a magnetic field concentrated in the iron ring.

The coil on the right is connected to a galvanometer G , which can indicate the presence of an induced current in that circuit. It is observed that there is no deflection in G for a steady current flow but when the switch S in the left circuit is closed, the galvanometer shows deflection for a moment. Similarly, when switch S is opened, momentary deflection is recorded but in opposite direction. It means that current is induced only when the magnetic field due to the current in the circuit on the left **changes**.

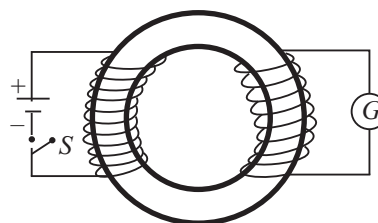

Fig. 19.1: Two coils are wrapped around an iron ring. The galvanometer G deflects for a moment when the switch is opened or closed.

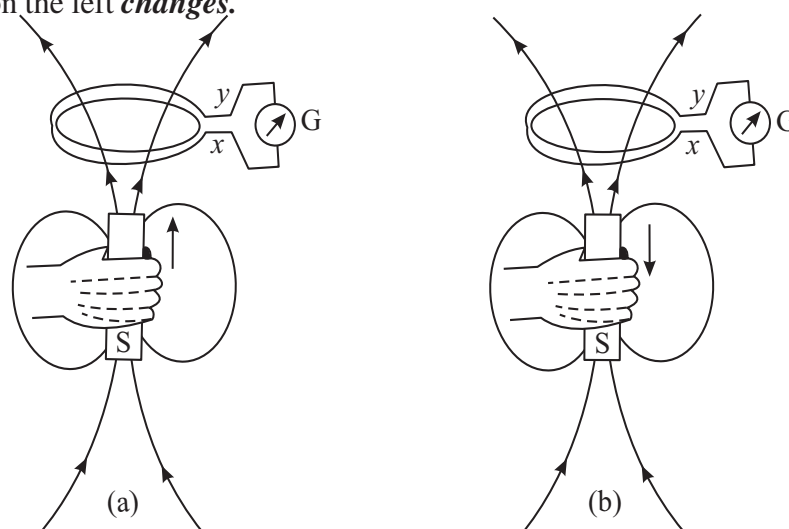

Fig. 19.2 : a) A current is induced in the coil if the magnet moves towards the coil, and b) the induced current has opposite direction if the magnet moves away from the coil.

MODULE - 5

Electricity and Magnetism



Notes

Electromagnetic Induction and Alternating Current

The importance of a change can also be demonstrated by the arrangement shown in Fig. 19.2. If the magnet is at rest relative to the coil, no current is induced in the coil. But when the magnet is moved towards the coil, current is induced in the direction indicated in Fig. 19.2a. Similarly, if the magnet is moved away from the coil, the a current is induced in the opposite direction, as shown in Fig.19.2b. Note that in both cases, the magnetic field changes in the neighbourhood of the coil. An induced current is also observed to flow through the coil, if this is moved relative to the magnet. The presence of such currents in a circuit implies the existence of an *induced electromotive force (emf)* across the free ends of the coil, i.e., x and y .

This phenomenon in which a magnetic field induces an emf is termed as *electromagnetic induction*. Faraday's genius recognised the significance of this work and followed it up. The quantitative description of this phenomenon is known as Faraday's law of electromagnetic induction. We will discuss it now.

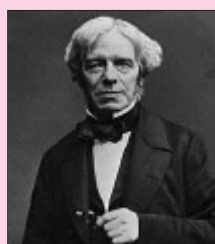

Michael Faraday (1791-1867)

British experimental scientist Michael Faraday is a classical example of a person who became great by sheer hardwork, perseverance, love for science and humanity. He started his carrier as an apprentice with a book binder, but utilized the opportunity to read science books that he received for binding. He sent his notes to Sir Humphry Davy, who immediately recognised the talent in the young man and appointed him his permanent assistant in the Royal Institute.

Sir Humphry Davy once admitted that the greatest discovery of his life was Michael Faraday. And he was right because Faraday made basic discoveries which led to the electrical age. It is because of his discoveries that electrical generators, transformers, electrical motors, and electolysis became possible.

19.1.1 Faraday's Law of Electromagnetic Induction

The relationship between the changing magnetic field and the induced emf is expressed in terms of magnetic flux ϕ_B linked with the surface of the coil. You will now ask: What is magnetic flux? To define *magnetic flux* ϕ_B refer to Fig. 19.3a, which shows a typical infinitesimal element of area $d\mathbf{s}$, into which the given surface can be considered to be divided. The direction of $d\mathbf{s}$ is normal to the surface at that point. By analogy with electrostatics, we can define the magnetic flux $d\phi_B$ for the area element $d\mathbf{s}$ as

$$d\phi_B = \mathbf{B} \cdot d\mathbf{s} \quad (19.1a)$$

The magnetic flux for the entire surface is obtained by summing such contributions over the surface. Thus,

$$d\phi_B = \sum \mathbf{B} \cdot d\mathbf{s} \quad (19.1b)$$

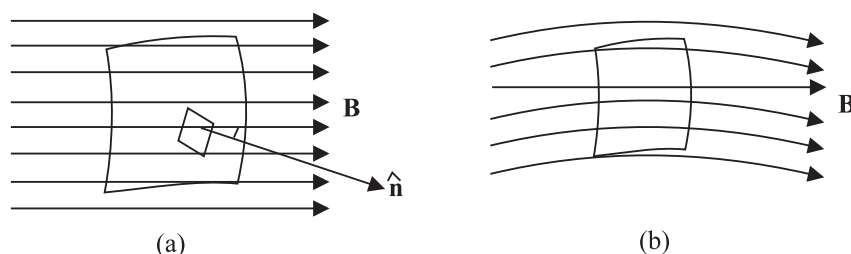

Fig. 19.3: a) The magnetic flux for an infinitesimal area ds is given by $d\phi_B = \mathbf{B} \cdot d\mathbf{s}$, and b) The magnetic flux for a surface is proportional to the number of lines intersecting the surface.

The SI unit of magnetic flux is **weber** (Wb), where $1 \text{ Wb} = 1 \text{ Tm}^2$.

In analogy with electric lines and as shown in Fig.19.3b, the number of magnetic lines intersecting a surface is proportional to the magnetic flux through the surface.

Faraday's law states that *an emf is induced across a loop of wire when the magnetic flux linked with the surface bound by the loop changes with time. The magnitude of induced emf is proportional to the rate of change of magnetic flux.* Mathematically, we can write

$$|\varepsilon| = \frac{d\phi_B}{dt} \quad (19.3)$$

From this we note that weber (Wb), the unit of magnetic flux and volt (V), the unit of emf are related as $1 \text{ V} = 1 \text{ Wb s}^{-1}$.

Now consider that an emf is induced in a closely wound coil. Each turn in such a coil behaves approximately as a single loop, and we can apply Faraday's law to determine the emf induced in each turn. Since the turns are in series, the total induced emf ε_r in a coil will be equal to the sum of the emfs induced in each turn. We suppose that the coil is so closely wound that the magnetic flux linking each turn of the coil has the same value at a given instant. Then the same emf ε is induced in each turn, and the total induced emf for a coil with N turns is given by

$$|\varepsilon_r| = N|\varepsilon| = N \left(\frac{d\phi_B}{dt} \right) \quad (19.4)$$

where ϕ_B is the magnetic flux linked with a single turn of the coil.

Let us now apply Faraday's law to some concrete situations.

Example 19.1 : The axis of a 75 turn circular coil of radius 35mm is parallel to a uniform magnetic field. The magnitude of the field changes at a constant rate



Notes

MODULE - 5

Electricity and Magnetism



Notes

Electromagnetic Induction and Alternating Current

from 25mT to 50 mT in 250 millisecond. Determine the magnitude of induced emf in the coil in this time interval.

Solution : Since the magnetic field is uniform and parallel to the axis of the coil, the flux linking each turn is given by

$$\phi_B = B\pi R^2$$

where R is radius of a turn. Using Eq. (19.4), we note that the induced emf in the coil is given by

$$|\varepsilon_r| = N \frac{d\phi_B}{dt} = N \frac{d(B\pi R^2)}{dt} = N \pi R^2 \frac{dB}{dt} = N \pi R^2 \left(\frac{B_2 - B_1}{t} \right)$$

Hence, the magnitude of the emf induced in the coil is

$$|\varepsilon_r| = 75\pi (0.035\text{m})^2 (0.10\text{Ts}^{-1}) = 0.030\text{V} = 30\text{mV}$$

This example explains the concept of emf induced by a time changing magnetic field.

Example 19.2 : Consider a long solenoid with a cross-sectional area 8cm^2 (Fig. 19.4a and 19.4b). A time dependent current in its windings creates a magnetic field $B(t) = B_0 \sin 2\pi\nu t$. Here B_0 is constant, equal to 1.2 T. and ν , the frequency of the magnetic field, is 50 Hz. If the ring resistance $R = 1.0\Omega$, calculate the emf and the current induced in a ring of radius r concentric with the axis of the solenoid.

Solution : We are told that magnetic flux

$$\phi_B = B_0 \sin 2\pi\nu t A$$

since normal to the cross sectional area of the solenoid is in the direction of magnetic field.

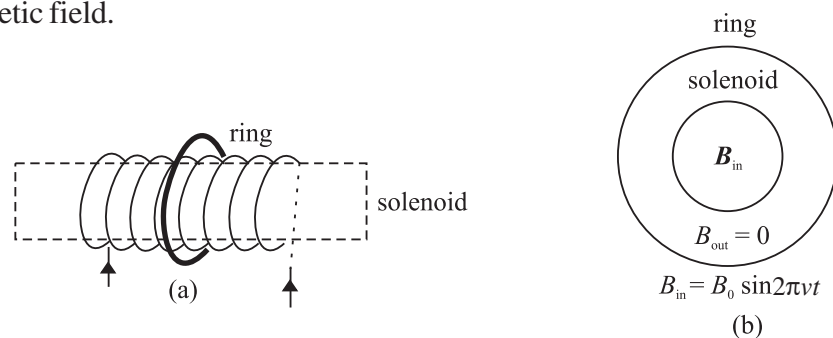

Fig.19.4 : a) A long solenoid and a concentric ring outside it, and b) cross-sectional view of the solenoid and concentric ring.

$$\begin{aligned} \text{Hence } |\varepsilon| &= \frac{d\phi_B}{dt} = 2\pi\nu AB_0 \cos 2\pi\nu t. \\ &= 2\pi \cdot (50\text{s}^{-1}) (8 \times 10^{-4}\text{m}^2) (1.2 \text{ T}) \cos 2\pi\nu t \\ &= 0.3 \cos 2\pi\nu t \text{ volts} \\ &= 0.3 \cos 100\pi t \text{ V} \end{aligned}$$

The current in the ring is $I = \varepsilon/R$. Therefore

$$I = \frac{(0.3 \cos 100\pi t) \text{ V}}{(1.0\Omega)}$$

$$= +0.3 \cos 100\pi t \text{ A}$$



INTEXT QUESTIONS 19.1

1. A 1000 turn coil has a radius of 5 cm. Calculate the emf developed across the coil if the magnetic field through the coil is reduced from 10 T to 0 in (a) 1 s (b) 1 ms.
2. The magnetic flux linking each loop of a 250-turn coil is given by $\phi_B(t) = A + Dt^2$, where $A = 3 \text{ Wb}$ and $D = 15 \text{ Wbs}^{-2}$ are constants. Show that a) the magnitude of the induced emf in the coil is given by $\varepsilon = (2ND)t$, and b) evaluate the emf induced in the coil at $t = 0\text{s}$ and $t = 3.0\text{s}$.
3. The perpendicular to the plane of a conducting loop makes a fixed angle θ with a spatially uniform magnetic field. If the loop has area S and the magnitude of the field changes at a rate dB/dt , show that the magnitude of the induced emf in the loop is given by $\varepsilon = (dB/dt) S \cos\theta$. For what orientation(s) of the loop will ε be a) maximum and b) minimum?

19.1.2 Lenz's Law

Consider a bar magnet approaching a conducting ring (Fig.19.5a). To apply Faraday's law to this system, we first choose a positive direction with respect to the ring. Let us take the direction from O to Z as positive. (Any other choice is fine, as long as we are consistent.) For this configuration, the positive normal for the area of the ring is in the z -direction and the magnetic flux is negative. As the distance between the conducting ring and the N-pole of the bar magnet decreases, more and more field lines go through the ring, making the flux more and more negative. Thus $d\phi_B/dt$ is negative. By Faraday's law, ε is positive relative to our chosen direction. The current I is directed as shown.

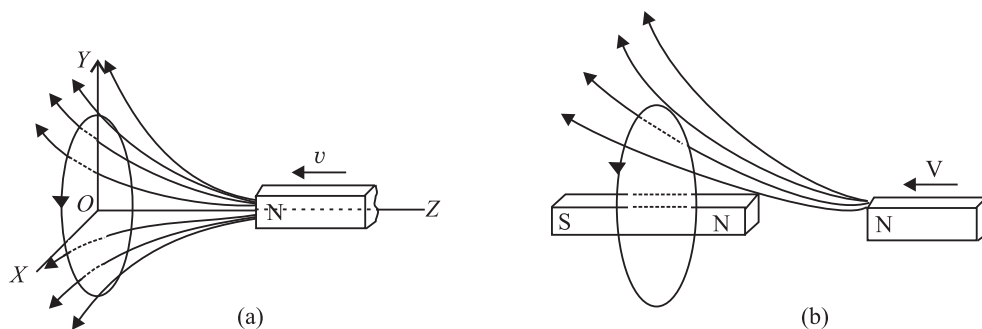

Fig.19.5: a) A bar magnet approaching a metal ring, and b) the magnetic field of the induced current opposes the approaching bar magnet.



Notes



Notes

The current induced in the ring creates a secondary magnetic field in it. This induced magnetic field can be taken as produced by a bar magnet, as shown in Fig.19.5 (b). Recall that induced magnetic field repels or opposes the original magnetic field. This opposition is a consequence of the law of conservation of energy, and is formalized as Lenz's law. **When a current is induced in a conductor, the direction of the current will be such that its magnetic effect opposes the change that induced it.**

The key word in the statement is 'oppose'-it tells us that we are not going to get something for nothing. When the bar magnet is pushed towards the ring, the current induced in the ring creates a magnetic field that opposes the change in flux. The magnetic field produced by the induced current repels the incoming magnet. If we wish to push the magnet towards the ring, we will have to do work on the magnet. This work shows up as electrical energy in the ring. Lenz's law thus follows from the law of conservation of energy. We can express the combined form of Faraday's and Lenz's laws as

$$\varepsilon = -\frac{d\phi}{dt} \quad (19.5)$$

The negative sign signifies opposition to the cause.

As an application of Lenz's law, let us reconsider the coil shown in Example 19.2. Suppose that its axis is chosen in vertical direction and the magnetic field is directed along it in upward direction. To an observer located directly above the coil, what would be the sense of the induced emf? It will be clockwise because only then the magnetic field due to it (directed downward by the right-hand rule) will oppose the changing magnetic flux. You should learn to apply Lenz's law before proceeding further. Try the following exercise.

19.1.3 Eddy currents

We know that the induced currents are produced in closed loops of conducting wires when the magnetic flux associated with them changes. However, induced currents are also produced when a solid conductor, usually in the form of a sheet or plate, is placed in a changing magnetic field. Actually, induced closed loops of currents are set up in the body of the conductor due to the change of flux linked with it. These currents flow in closed paths and in a direction perpendicular to the magnetic flux. These currents are called eddy currents as they look like eddies or whirlpools and also sometimes called Foucault currents as they were first discovered by Foucault.

The direction of these currents is given by Lenz's law according to which the direction will be such as to oppose the flux to which the induced currents are due. Fig. 19.1.3 shows some of the eddy currents in a metal sheet placed in

an increasing magnetic field pointing into the plane of the paper. The eddy currents are circular and point in the anticlockwise direction.

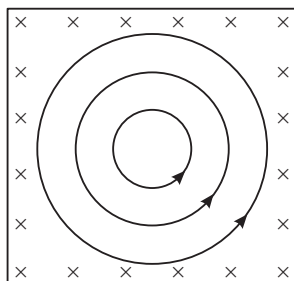

Fig. 19.1.3

The eddy currents produced in metallic bodies encounter little resistance and, therefore, have large magnitude. Obviously, eddy currents are considered undesirable in many electrical appliances and machines as they cause appreciable energy loss by way of heating. Hence, to reduce these currents, the metallic bodies are not taken in one solid piece but are rather made in parts or strips, called lamination, which are insulated from one another.

Eddy currents have also been put to some applications. For example, they are used in induction furnaces for making alloys of different metals in vacuum. They are also used in electric brakes for stopping electric trains.



INTEXT QUESTIONS 19.2

- The bar magnet in Fig.19.6 moves to the right. What is the sense of the induced current in the stationary loop A? In loop B?
- A cross-section of an ideal solenoid is shown in Fig.19.7. The magnitude of a uniform magnetic field is increasing inside the solenoid and $\mathbf{B} = 0$ outside the solenoid. which conducting loops is there an induced current? What is the sense of the current in each case?
- A bar magnet, with its axis aligned along the axis of a copper ring, is moved along its length toward the ring. Is there an induced current in the ring? Is there an induced electric field in the ring? Is there a magnetic force on the bar magnet? Explain.
- Why do we use laminated iron core in a transformer.

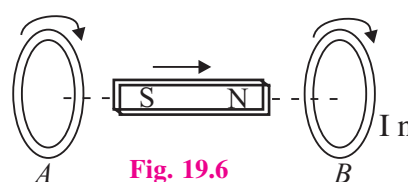

Fig. 19.6

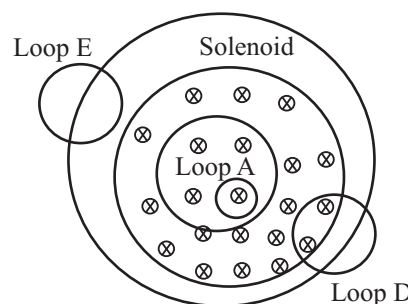

Fig. 19.7



Notes



Notes

19.2 INDUCTANCE

When current in a circuit changes, a changing magnetic field is produced around it. If a part of this field passes through the circuit itself, current is induced in it. Now suppose that another circuit is brought in the neighbourhood of this circuit. Then the magnetic field through that circuit also changes, inducing an emf across it. Thus, induced emfs can appear in these circuits in two ways:

- By changing current in a coil, the magnetic flux linked with each turn of the coil changes and hence an induced emf appears across that coil. This property is called *self-induction*.
- for a pair of coils situated close to each other such that the flux associated with one coil is linked through the other, a changing current in one coil induces an emf in the other. In this case, we speak of *mutual induction* of the pair of coils.

19.2.1 Self-Inductance

Let us consider a loop of a conducting material carrying electric current. The current produces a magnetic field **B**. The magnetic field gives rise to magnetic flux. The total magnetic flux linking the loop is

$$d\phi = \mathbf{B} \cdot d\mathbf{s}$$

In the absence of any external source of magnetic flux (for example, an adjacent coil carrying a current), the Biot-Savart’s law tells us that the magnetic field and hence flux will be proportional to the current (*I*) in the loop, i.e.

$$\phi \propto I \quad \text{or} \quad \phi = LI \tag{19.6}$$

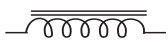
where *L* is called self-inductance of the coil. The circuit elements which oppose change in current are called *inductors*. These are in general, in the form of coils of varied shapes and sizes. The symbol for an *inductor* is . If the coil is wrapped around an iron core so as to enhance its magnetic effect, it is symbolised by putting two lines above it, as shown here . The inductance of an indicator depends on its geometry.

(a) Faraday’s Law in terms of Self-Inductance: So far you have learnt that if current in a loop changes, the magnetic flux linked through it also changes and gives rise to self-induced emf between the ends. In accordance with Lenz’s law, the self-induced emf opposes the change that produces it.

To express the combined form of Faraday’s and Lenz’s Laws of induction in terms of *L*, we combine Eqns. (19.5) and (19.6) to obtain

$$\epsilon = -\frac{d\phi}{dt} = -L \frac{dI}{dt} \tag{19.7a}$$

$$= -L \left(\frac{I_2 - I_1}{t} \right) \tag{19.7b}$$

where I_1 and I_2 respectively denote the initial and final values of current at $t = 0$ and $t = \tau$. Using Eqn. (19.7b), we can define the unit of self-inductance:

$$\begin{aligned} \text{units of } L &= \frac{\text{unit of emf}}{\text{units of } dI/dt} \\ &= \frac{\text{volt}}{\text{ampere / second}} \\ &= \text{ohm-second} \end{aligned}$$

An ohm-second is called a *henry*, (abbreviated H). For most applications, henry is a rather large unit, and we often use millihenry, mH (10^{-3} H) and microhenry μH (10^{-6} H) as more convenient measures.

The self-induced emf is also called the **back emf**. Eqn.(19.7a) tells us that the **back emf in an inductor** depends on the rate of change of current in it and **opposes the change in current**. Moreover, since an infinite emf is not possible, from Eq.(19.7b) we can say that an instantaneous change in the inductor current cannot occur. Thus, we conclude that **current through an inductor cannot change instantaneously**.

The inductance of an inductor depends on its geometry. In principle, we can calculate the self-inductance of any circuit, but in practice it is difficult except for devices with simple geometry. A solenoid is one such device used widely in electrical circuits as inductor. Let us calculate the self-inductance of a solenoid.

(b) Self-inductance of a solenoid : Consider a long solenoid of cross-sectional area A and length ℓ , which consists of N turns of wire. To find its inductance, we must relate the current in the solenoid to the magnetic flux through it. In the preceding lesson, you used Ampere's law to determine magnetic field of a long solenoid:

$$|\mathbf{B}| = \mu_0 n I$$

where $n = N/\ell$ denotes is the number of turns per unit length and I is the current through the solenoid.

The total flux through N turns of the solenoid is

$$\phi = N |\mathbf{B}| A = \frac{\mu_0 N^2 A I}{\ell} \quad (19.8)$$

and self-inductance of the solenoid is

$$L = \frac{\phi}{I} = \frac{\mu_0 N^2 A}{\ell} \quad (19.9)$$



Notes

MODULE - 5

Electricity and Magnetism



Notes

Electromagnetic Induction and Alternating Current

Using this expression, you can calculate self-inductance and back emf for a typical solenoid to get an idea of their magnitudes.



INTEXT QUESTIONS 19.3

1. A solenoid 1m long and 20cm in diameter contains 10,000 turns of wire. A current of 2.5A flowing in it is reduced steadily to zero in 1.0ms. Calculate the magnitude of back emf of the inductor while the current is being reduced.
2. A certain length (ℓ) of wire, folded into two parallel, adjacent strands of length $\ell/2$, is wound on to a cylindrical insulator to form a type of wire-wound non-inductive resistor (Fig.19.8). Why is this configuration called non-inductive?
3. What rate of change of current in a 9.7 mH solenoid will produce a self-induced emf of 35mV?

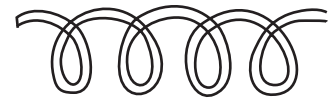

Fig.19.8: Wire wound on a cylindrical insulator

19.2.2 LR Circuits

Suppose that a solenoid is connected to a battery through a switch (Fig.19.9). Beginning at $t = 0$, when the switch is closed, the battery causes charges to move in the circuit. A solenoid has inductance (L) and resistance (R), and each of these influence the current in the circuit. The inductive and resistive effects of a solenoid are shown schematically in Fig.19.10. The inductance (L) is shown in series with the resistance (R). For simplicity, we assume that total resistance in the circuit, including the internal resistance of the battery, is represented by R . Similarly, L includes the self-inductance of the connecting wires. A circuit such as that shown in Fig.19.9, containing resistance and inductance in series, is called an LR circuit.

The role of the inductance in any circuit can be understood qualitatively. As the current $i(t)$ in the circuit increases (from $i = 0$ at $t = 0$), a self-induced emf $\epsilon = -L di/dt$ is produced in the inductance whose sense is opposite to the sense of the increasing current. This opposition to the increase in current prevents the current from rising abruptly.

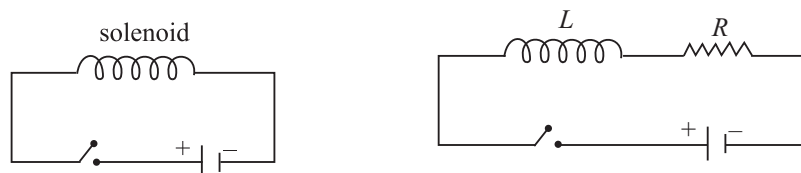

Fig. 19.9: LR Circuit



Notes

If there been no inductance in the circuit, the current would have jumped immediately to the maximum value defined by ϵ_0/R . But due to an inductance coil in the circuit, the current rises gradually and reaches a steady state value of ϵ_0/R as $t \rightarrow \tau$. The time taken by the current to reach about two-third of its steady state value is equal to L/R , which is called the **inductive time constant** of the circuit. Significant changes in current in an LR circuit cannot occur on time scales much shorter than L/R . The plot of the current with time is shown in Fig. 19.10.

You can see that greater the value of L , the larger is the back emf, and longer it takes the current to build up. (This role of an inductance in an electrical circuit is somewhat similar to that of mass in mechanical systems.) That is why while switching off circuits containing large inductors, you should be mindful of back emf. The spark seen while turning off a switch connected to an electrical appliance such as a fan, computer, geyser or an iron, essentially arises due to back emf.

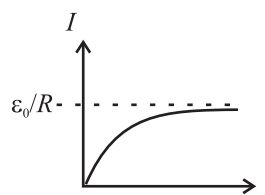

Fig.19.10 : Variation of current with time in a LR-circuit.



INTEXT QUESTIONS 19.4

1. A light bulb connected to a battery and a switch comes to full brightness almost instantaneously when the switch is closed. However, if a large inductance is in series with the bulb, several seconds may pass before the bulb achieves full brightness. Explain why.
2. In an LR circuit, the current reaches 48mA in 2.2 ms after the switch is closed. After sometime the current reaches its steady state value of 72mA. If the resistance in the circuit is 68Ω , calculate the value of the inductance.

19.2.3 Mutual Inductance

When current changes in a coil, a changing magnetic flux develops around it, which may induce emf across an adjoining coil. As we see in Fig. (19.11), the magnetic flux linking each turn of coil B is due to the magnetic field of the current in coil A .

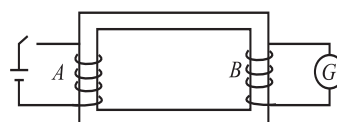

Fig. 19.11 : Mutual inductance of a pair of coils

Therefore, a changing current in each coil induces an emf in the other coil, i.e.

$$\text{i.e.,} \quad \phi_2 \propto \phi_1 \propto I_1 \Rightarrow \phi_2 = MI_1 \quad (19.10)$$

MODULE - 5

Electricity and Magnetism

Electromagnetic Induction and Alternating Current



Notes

where M is called the mutual inductance of the pair of coils. Also back emf induced across the second coil

$$\begin{aligned}e_2 &= -\frac{d\phi}{dt} \\ &= -M \frac{dI}{dt} = -M \left(\frac{I_2 - I_1}{t} \right)\end{aligned}\quad (19.11)$$

where the current in coil A changes from I_1 to I_2 in t seconds.

The mutual inductance depends only on the geometry of the two coils, if no magnetic materials are nearby. The SI unit of mutual inductance is also henry (H), the same as the unit of self-inductance.

Example 19.3 : A coil in one circuit is close to another coil in a separate circuit. The mutual inductance of the combination is 340 mH. During a 15 ms time interval, the current in coil 1 changes steadily from 28 mA to 57 mA and the current in coil 2 changes steadily from 36 mA to 16 mA. Determine the emf induced in each coil by the changing current in the other coil.

Solution : During the 15 ms time interval, the currents in the coils change at the constant rates of

$$\begin{aligned}\frac{di_1}{dt} &= \frac{57\text{mA} - 23\text{mA}}{15\text{ms}} = 2.3 \text{ As}^{-1} \\ \frac{di_2}{dt} &= \frac{16\text{mA} - 36\text{mA}}{15\text{ms}} = -1.3 \text{ As}^{-1}\end{aligned}$$

From Eq. (19.11), we note that the magnitudes of the induced emfs are

$$\varepsilon_1 = - (340\text{mH}) (2.3\text{As}^{-1}) = -0.78 \text{ V}$$

$$\varepsilon_2 = (340\text{mH}) (1.3\text{As}^{-1}) = 0.44 \text{ V}$$

Remember that the minus signs in Eq. (19.11) refer to the sense of each induced emf.

One of the most important appliances based on the phenomenon of mutual inductance is transformer. You will learn about it later in this lesson. Some commonly used devices based on self-inductance are the choke coil and the ignition coil. We will discuss about these devices briefly. Later, you will also learn that a combination of inductor and capacitor acts as a basic oscillator. Once the capacitor is charged, the charge in this arrangement oscillates between its two plates through the inductor.



INTEXT QUESTIONS 19.5

1. Consider the sense of the mutually induced emf's in Fig.19.11, according to an observer located to the right of the coils. (a) At an instant when the current i_1 is increasing, what is the sense of emf across the second coil? (b) At an instant when i_2 is decreasing, what is the sense of emf across the first coil?
2. Suppose that one of the coils in Fig.19.11 is rotated so that the axes of the coils are perpendicular to each other. Would the mutual inductance remain the same, increase or decrease? Explain.



Notes

19.3 ALTERNATING CURRENTS AND VOLTAGES

When a battery is connected to a resistor, charge flows through the resistor in one direction only. If we want to reverse the direction of the current, we have to interchange the battery connections. However, the magnitude of the current will remain constant. Such a current is called *direct current*. But a current whose magnitude changes continuously and direction changes periodically, is said to be an *alternating current* (Fig. 19.12).

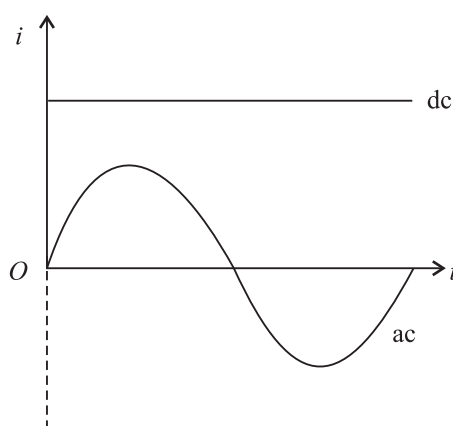

Fig. 19.12 : dc and ac current waveforms

In general, alternating voltage and currents are mathematically expressed as

$$V = V_m \cos \omega t \quad (19.12a)$$

and

$$I = I_m \cos \omega t \quad (19.12b)$$

V_m and I_m are known as the **peak values** of the alternating voltage and current respectively. In addition, we also define the root mean square (*rms*) values of V and I as

$$V_{\text{rms}} = \frac{V_m}{\sqrt{2}} = 0.707 V_m \quad (19.13a)$$

MODULE - 5

Electricity and Magnetism



Notes

Electromagnetic Induction and Alternating Current

$$I_{\text{rms}} = \frac{I_m}{\sqrt{2}} = 0.707 I_m \quad (19.13b)$$

The relation between V and I depends on the circuit elements present in the circuit. Let us now study a.c. circuits containing (i) a resistor (ii) a capacitor, and (iii) an inductor only

George Westinghouse

(1846-1914)



If ac prevails over dc all over the world today, it is due to the vision and efforts of George Westinghouse. He was an American inventor and entrepreneur having about 400 patents to his credit. His first invention was made when he was only fifteen year old. He invented air brakes and automatic railway signals, which made railway traffic safe.

When Yugoslav inventor Nicole Tesla (1856-1943) presented the idea of rotating magnetic field, George Westinghouse immediately grasped the importance of his discovery. He invited Tesla to join him on very lucrative terms and started his electric company. The company shot into fame when he used the energy of Niagra falls to produce electricity and used it to light up a town situated at a distance of 20km.

19.3.1 AC Source Connected to a Resistor

Refer to Fig. 19.13 which shows a resistor in an ac circuit. The instantaneous value of the current is given by the instantaneous value of the potential difference across the resistor divided by the resistance.

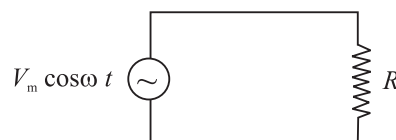

Fig. 19.13 : An ac circuit containing a resistor

$$\begin{aligned} I &= \frac{V}{R} \\ &= \frac{V_m \cos \omega t}{R} \end{aligned} \quad (19.14a)$$

The quantity V_m/R has units of volt per ohm, (i.e., ampere). It represents the maximum value of the current in the circuit. The current changes direction with time, and so we use positive and negative values of the current to represent the two possible current directions. Substituting I_m , the maximum current in the circuit, for V_m/R in Eq. (19.14a), we get

$$I = I_m \cos \omega t \quad (19.14b)$$

Fig.19.14 shows the time variation of the potential difference between the ends of a resistor and the current in the resistor. Note that the potential difference and current are in phase i.e., the peaks and valleys occur at the same time.

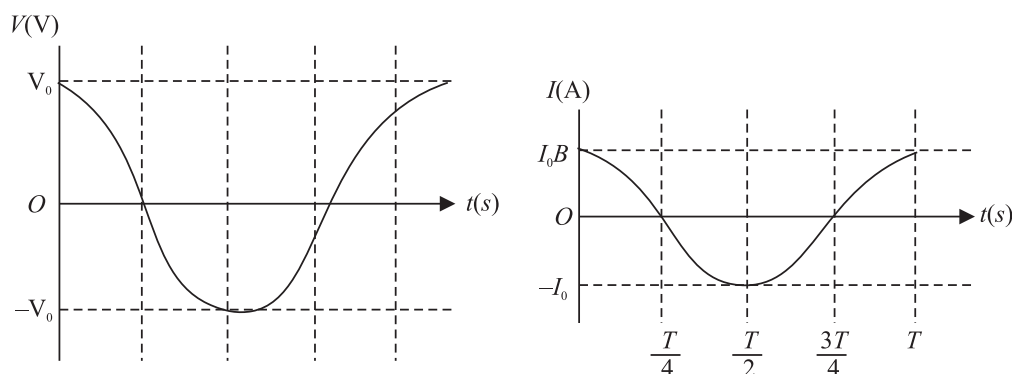

Fig. 19.14 : Time variation of current and voltage in a purely resistive circuit

In India, we have $V_m = 310\text{V}$ and $\nu = 50\text{ Hz}$. Therefore for $R = 10\ \Omega$, we get

$$V = 310 \cos (2\pi 50t)$$

and

$$\begin{aligned} I &= \frac{310}{10} \cos (100\pi t) \\ &= 31 \cos (100\pi t)\text{A} \end{aligned}$$

Since V and I are proportional to $\cos (100\pi t)$, the average current is zero over an integral number of cycles.

The **average power** $P = I^2 R$ developed in the resistor is not zero, because square of instantaneous value of current is always positive. As I^2 , varies periodically between zero and I^2 , we can determine the average power, P_{av} , for single cycle:

$$P_{av} = (I^2 R)_{av} = R(I^2)_{av} = R \left(\frac{I_m^2 + 0}{2} \right)$$

$$P_{av} = R \left(\frac{I_m^2}{2} \right) = R I_{rms}^2 \quad (19.15)$$

Note that the same power would be produced by a constant *dc* current of value $(I_m/\sqrt{2})$ in the resistor. It would also result if we were to connect the resistor to a potential difference having a constant value of $V_m/\sqrt{2}$ volt. The quantities $I_m/\sqrt{2}$ and $V_m/\sqrt{2}$ are called the rms values of the current and potential difference. The term rms is short for root-mean-square, which means “the square root of the mean value of the square of the quantity of interest.” For an electric outlet in an Indian home where $V_m = 310\text{V}$, the rms value of the potential difference is

$$V_{rms} = V_m/\sqrt{2} \simeq 220\text{V}$$



Notes

MODULE - 5

Electricity and
Magnetism



Notes

Electromagnetic Induction and Alternating Current

This is the value generally quoted for the potential difference. Note that when potential difference is 220 V, the peak value of a.c voltage is 310V and that is why it is so fatal.



INTEXT QUESTIONS 19.6

1. In a light bulb connected to an ac source the instantaneous current is zero two times in each cycle of the current. Why does the bulb not go off during these times of zero current?
2. An electric iron having a resistance 25Ω is connected to a 220V, 50 Hz household outlet. Determine the average current over the whole cycle, peak current, instantaneous current and the rms current in it.
3. Why is it necessary to calculate root mean square values of ac current and voltage.

19.3.2 AC Source Connected to a Capacitor

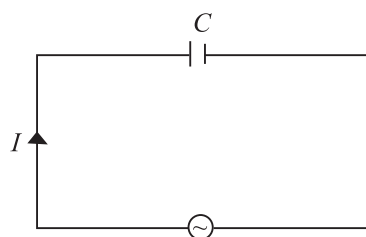

Fig.19.15 : Capacitor in an ac circuit

Fig.19.15 shows a capacitor connected to an ac source. From the definition of capacitance, it follows that the instantaneous charge on the capacitor equals the instantaneous potential difference across it multiplied by the capacitance ($q = CV$). Thus, we can write

$$q = CV_m \cos \omega t \quad (19.16)$$

Since $I = dq/dt$, we can write

$$I = -\omega CV_m \sin \omega t \quad (19.17)$$

Time variation of V and I in a capacitive circuit is shown in Fig.19.16.

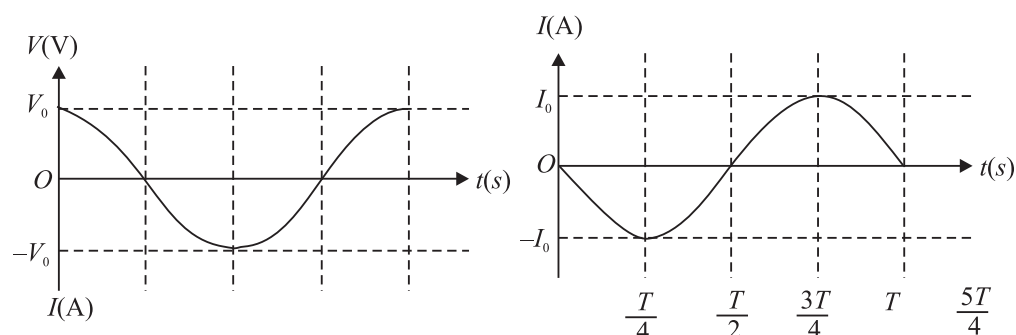

Fig.19.16: Variation in V and I with time in a capacitive circuit

Unlike a resistor, the current I and potential difference V for a capacitor are not in phase. The first peak of the current-time plot occurs one quarter of a cycle before



Notes

the first peak in the potential difference-time plot. Hence we say that the capacitor current leads capacitor potential difference by one quarter of a period. One quarter of a period corresponds to a phase difference of $\pi/2$ or 90° . Accordingly, we also say that the potential difference lags the current by 90° .

Rewriting Eq. (19.17) as

$$I = -\frac{V_m}{1/(\omega C)} \sin \omega t \quad (19.18)$$

and comparing Eqs. (19.14a) and (19.18), we note that $(1/\omega C)$ must have units of resistance. The quantity $1/\omega C$ is called the capacitive reactance, and is denoted by the symbol X_C :

$$\begin{aligned} X_C &= \frac{1}{\omega C} \\ &= \frac{1}{2\pi\nu C} \end{aligned} \quad (19.19)$$

Capacitive reactance is a measure of the extent to which the capacitor limits the ac current in the circuit. It depends on capacitance and the frequency of the generator. The capacitive reactance decreases with increase in frequency and capacitance. Resistance and capacitive reactance are similar in the sense that both measure limitations to ac current. But unlike resistance, capacitive reactance depends on the frequency of the ac (Fig.19.17). The concept of capacitive reactance allows us to introduce an equation analogous to the equation $I = V/R$:

$$I_{\text{rms}} = \frac{V_{\text{rms}}}{X_C} \quad (19.20)$$

The instantaneous power delivered to the capacitor is the product of the instantaneous capacitor current and the potential difference :

$$\begin{aligned} P &= VI \\ &= -\omega CV^2 \sin \omega t \cos \omega t \\ &= -\frac{1}{2} \omega CV^2 \sin 2\omega t \end{aligned} \quad (19.21)$$

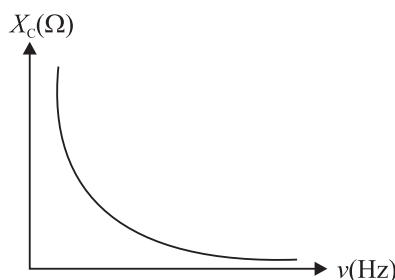

Fig.19.17 : Frequency variation of capacitive reactance

The sign of P determines the direction of energy flow with time. When P is positive, energy is stored in the capacitor. When P is negative, energy is released by the capacitor. Graphical representations of V , I , and P are shown in Fig.19.18. Note

MODULE - 5

Electricity and Magnetism



Notes

Electromagnetic Induction and Alternating Current

that whereas both the current and the potential difference vary with angular frequency ω , the power varies with angular frequency 2ω . The average power is zero. The electric energy stored in the capacitor during a charging cycle is completely recovered when the capacitor is discharged. On an average, there is no energy stored or lost in the capacitor in a cycle.

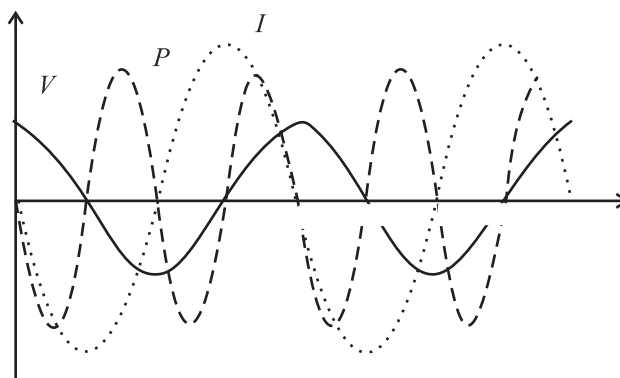

Fig.19.18 : Time variation of V , I and P

Example 19.5 : A $100 \mu\text{F}$ capacitor is connected to a 50Hz ac generator having a peak amplitude of 220V . Calculate the current that will be recorded by an rms ac ammeter connected in series with the capacitor.

Solution : The capacitive reactance of a capacitor is given by

$$X_C = \frac{1}{\omega C} = \frac{1}{2\pi(50 \text{ rads}^{-1})(100 \times 10^{-6} \text{ F})} = 31.8 \Omega$$

Assuming that ammeter does not influence the value of current because of its low resistance, the instantaneous current in the capacitor is given by

$$\begin{aligned} I &= \frac{V}{X_C} \cos \omega t = \frac{220}{31.8} \cos \omega t \\ &= (-6.92 \cos \omega t) \text{ A} \end{aligned}$$

The rms value of current is

$$\begin{aligned} I_{\text{rms}} &= \frac{I_m}{\sqrt{2}} \\ &= \frac{6.92}{\sqrt{2}} \\ &= 4.91 \text{ A} \end{aligned}$$

Now answer the following questions.

INTEXT QUESTIONS 19.7

1. Explain why current in a capacitor connected to an ac generator increases with capacitance.
2. A capacitor is connected to an ac generator having a fixed peak value (V_m) but variable frequency. Will you expect the current to increase as the frequency decreases?
3. Will average power delivered to a capacitor by an ac generator to be zero? Justify your answer.
4. Why do capacitive reactances become small in high frequency circuits, such as those in a TV set?



Notes
19.3.3 AC Source Connected to an Inductor

Fig.19.19 : An ac generator connected to an inductor

We now consider an ideal (zero-resistance) inductor connected to an ac source. (Fig. 19.19). If V is the potential difference across the inductor, we can write

$$V(t) = L \frac{dI(t)}{dt} = V_m \cos \omega t \quad (19.22)$$

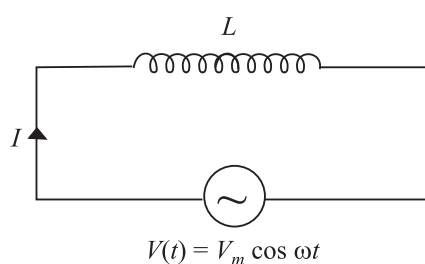
To integrate Eqn. (19.22) with time, we rewrite it as

$$\int dI = \frac{V_m}{L} \int \cos \omega t \, dt .$$

Since integral of $\cos x$ is $\sin x$, we get

$$I(t) = \frac{V_m}{\omega L} \sin \omega t + \text{constant} \quad (19.23a)$$

When $t = 0$, $I = 0$. Hence constant of integration becomes zero. Thus

$$I(t) = \frac{V_m}{\omega L} \sin \omega t \quad (19.23b)$$

To compare $V(t)$ and $I(t)$ let us take $V_m = 220\text{V}$, $\omega = 2\pi(50) \text{ rads}^{-1}$, and $L = 1\text{H}$. Then

$$V(t) = 220 \cos (2\pi 50t) \text{ volt}$$

$$I(t) = \frac{220}{2\pi \cdot 50} \sin (2\pi 50t) = 0.701 \sin (2\pi 50t) \text{ ampere}$$

Fig.19.20. Shows time variation of V and I The inductor current and potential difference across it are not in phase. In fact the potential difference peaks one-quarter cycle before the current. We say that in case of an inductor current lags

MODULE - 5

Electricity and Magnetism



Notes

Electromagnetic Induction and Alternating Current

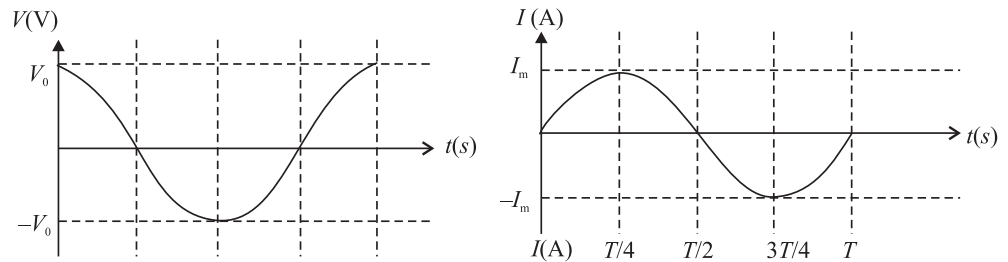

Fig. 19.20 : Time variation of the potential difference across an inductor and the current flowing through it. These are not in phase

the potential difference by $\pi/2$ rad (or 90°). This is what we would expect from Lenz's law. Another way of seeing this is to rewrite Eq. (19.23b) as

$$I = \frac{V_m}{\omega L} \cos\left(\omega t - \frac{\pi}{2}\right)$$

Because $V = V_m \cos \omega t$, the phase difference ($-\pi/2$) for I means that current lags voltage by $\pi/2$. This is in contrast to the current in a capacitor, which leads the potential difference. For an inductor, the current lags the potential difference.

The quantity ωL in Eq.(19.23b) has units of resistance and is called **inductive reactance**. It is denoted by symbol X_L :

$$X_L = \omega L = 2\pi\nu L \quad (19.24)$$

Like capacitive reactance, the inductive reactance, X_L , is expressed in ohm. **Inductive reactance** is a measure of the extent to which the inductor limits ac current in the circuit. It depends on the inductance and the frequency of the generator. Inductive reactance increases, if either frequency or inductance increases. (This is just the opposite of capacitive reactance.) In the limit frequency goes to zero, the inductive reactance goes to zero. But recall that as $\omega \rightarrow 0$, capacitive reactance tends to infinity (see Table 19.1). Because inductive effects vanish for a dc source, such as a battery, zero inductive reactance for zero frequency is consistent with the behaviour of an inductor connected to a dc source. The frequency variation of X_L is shown in Fig. 19.21.

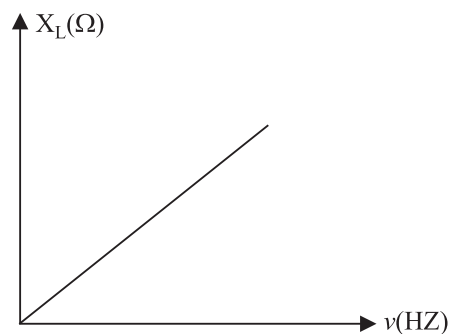

Fig.19.21 : The reactance of an inductor ($X_L = 2\pi\nu L$) as a function of frequency. The inductive reactance increases as the frequency increases.

Table 19.1: Frequency response of passive circuit elements

Circuit element	Opposition to flow of current	Value at low-frequency	Value at high-frequency
Resistor	R	R	R
Capacitor	$X_C = \frac{1}{\omega C}$	∞	0
Inductor	$X_L = \omega L$	0	∞

The concept of inductive reactance allows us to introduce an inductor analog in the equation $I = V/R$ involving resistance R :

$$I_{\text{rms}} = \frac{V_{\text{rms}}}{X_L} \quad (19.25)$$

The instantaneous power delivered to the inductor is given by

$$\begin{aligned} P &= VI \\ &= \frac{V_m^2}{\omega L} \sin \omega t \cos \omega t = \frac{V_m^2}{2\omega L} \sin 2\omega t \end{aligned} \quad (19.26)$$

Graphical representations of V , I and P for an inductor are shown in Fig. 19.21. Although both the current and the potential difference vary with angular frequency, the power varies with twice the angular frequency. The average power delivered over a whole cycle is zero. Energy is alternately stored and released as the magnetic field alternately grows and windles. decays

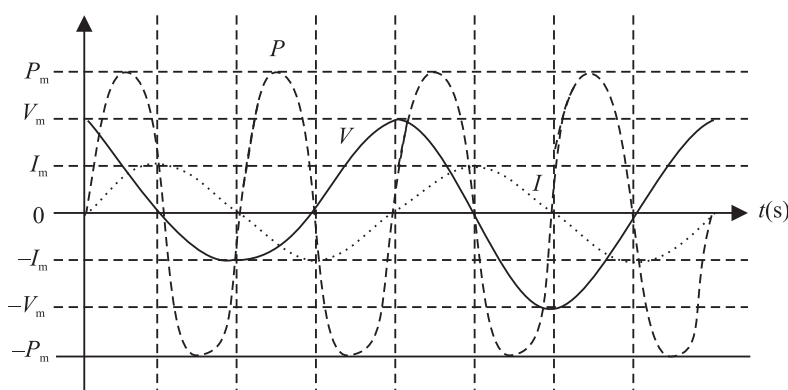

Fig. 19.21: Time variation of potential difference, current and power in an inductive circuit

Example 19.6 : An air cored solenoid has a length of 25cm and diameter of 2.5cm, and contains 1000 closely wound turns. The resistance of the coil is measured to be 1.00Ω . Compare the inductive reactance at 100Hz with the resistance of the coil.



Notes

MODULE - 5

Electricity and Magnetism



Notes

Electromagnetic Induction and Alternating Current

Solution : The inductance of a solenoid, whose length is large compared to its diameter, is given by

$$L = \frac{\mu_0 N^2 \pi a^2}{\ell}$$

where N denotes number of turns, a is radius, and ℓ is length of the solenoid. On substituting the given values, we get

$$\begin{aligned} L &= \frac{(4\pi \times 10^{-7}) \text{ Hm}^{-1} (1000)^2 \pi (0.0125)^2 \text{ m}^2}{0.25 \text{ m}} \\ &= 2.47 \times 10^{-3} \text{ H} \end{aligned}$$

The inductive reactance at a frequency of 100Hz is

$$\begin{aligned} X_L = \omega L &= 2\pi \left(100 \frac{\text{rad}}{\text{s}} \right) (2.47 \times 10^{-3}) \text{ H} \\ &= 1.55 \Omega \end{aligned}$$

Thus, inductive reactance of this solenoid at 100Hz is comparable to the intrinsic (ohmic) resistance R . In a circuit diagram, it would be shown as

$$L = 2.47 \text{ H and } R = 1.00 \Omega$$



You may now like to test your understanding of these ideas.



INTEXT QUESTIONS 19.8

1. Describe the role of Lenz's law when an ideal inductor is connected to an ac generator.
2. In section 19.3.1, self-inductance was characterised as electrical inertia. Using this as a guide, why would you expect current in an inductor connected to an ac generator to decrease as the self-inductance increases?

19.3.4 Series LCR Circuit

Refer to Fig. 19.22. It shows a circuit having an inductor L , a capacitor C and a resistor R in series with an ac source, providing instantaneous emf $E = E_m \sin \omega t$. The current through all the three circuit elements is the same in amplitude and phase but potential differences across each of them, as discussed earlier, are not in the same phase. Note that

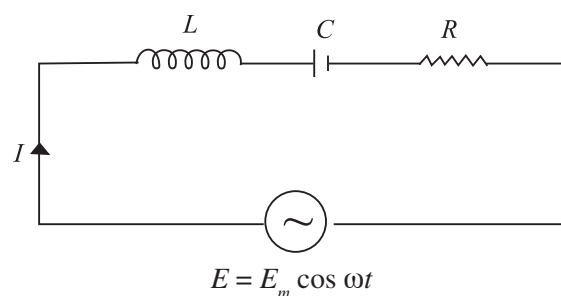
Fig. 19.22: A series LCR circuit

- (i) The potential difference across the resistor $V_R = I_0 R$ and it will be in-phase with current.
- (ii) Amplitude of P.D. across the capacitor $V_C = I_0 X_C$ and it lags behind the current by an angle $\pi/2$ and (iii) amplitude of P.D. across the inductor $V_L = I_0 X_L$ and it leads the current by an angle $\pi/2$.

Due to different phases, we can not add voltages algebraically to obtain the resultant peak voltage across the circuit. To add up these voltages, we draw a phasor diagram showing proper phase relationship of the three voltages (Fig.19.23). The diagram clearly shows that voltages across the inductor and capacitor are in opposite phase and hence net voltage across the reactive components is $(V_L - V_C)$. The resultant peak voltage across the circuit is therefore given by

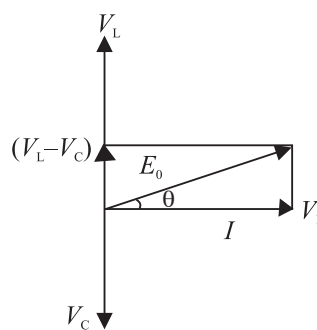
Fig. 19.23: Phasor diagram of voltages across LCR.

$$\begin{aligned} E_0 &= \sqrt{(V_L - V_C)^2 + V_R^2} \\ &= \sqrt{I_0^2 \{(X_L - X_C)^2 + R^2\}} \end{aligned}$$

or
$$\frac{E_0}{I_0} = \sqrt{(X_L - X_C)^2 + R^2}$$

The opposition to flow of current offered by a LCR circuit is called its *impedance*. The impedance of the circuit is given by

$$Z = \frac{E_{\text{rms}}}{I_{\text{rms}}} = \frac{E_0}{I_0} = \sqrt{(X_L - X_C)^2 + R^2} = \sqrt{\left(2\pi\nu L - \frac{1}{2\pi\nu C}\right)^2 + R^2} \quad (19.27)$$

Hence, the rms current across an LCR circuit is given by

$$I_{\text{rms}} = \frac{E_{\text{rms}}}{Z}$$



MODULE - 5

Electricity and Magnetism



Notes

Electromagnetic Induction and Alternating Current

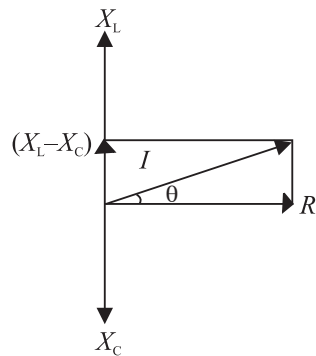

Fig. 19.24 : Phasor diagram for Z

Also from Fig.19.23 it is clear that in LCR circuit, the emf leads (or lags) the current by an angle ϕ , given by

$$\tan\phi = \frac{V_L - V_C}{V_R} = \frac{X_L I_0 - X_C I_0}{R I_0} = \frac{X_L - X_C}{R} \quad (19.28)$$

This means that R , X_L , X_C and Z can also be represented on a phasor diagram similar to voltage (Fig.19.24).

Resonance

You now know that inductive reactance (X_L) increases and capacitive reactance (X_C) decreases with increase in frequency of the applied ac source. Moreover, these are out of phase. Therefore, there may be a certain frequency ν_r for which $X_L = X_C$:

$$\begin{aligned} \text{i.e.} \quad 2\pi \nu_r L &= \frac{1}{2\pi \nu_r C} \\ \Rightarrow \nu_r &= \frac{1}{2\pi\sqrt{LC}} \end{aligned} \quad (19.29)$$

This frequency is called *resonance frequency* and at this frequency, impedance has minimum value: $Z_{\min} = R$. The circuit now becomes purely resistive. Voltage across the capacitor and the inductor, being equal in magnitude, annul each other. Since a resonant circuit is purely resistive, the net voltage is in phase with current ($\phi = 0$) and maximum current flows through the circuit. The circuit is said to be in resonance with applied ac. The graphs given in Fig.19.25 show the variation of peak value of current in an LCR circuit with the variation of the frequency of the applied source. The resonance frequency of a given LCR circuit is independent of resistance. But as shown in Fig.19.25, the peak value of current increases as resistance decreases.

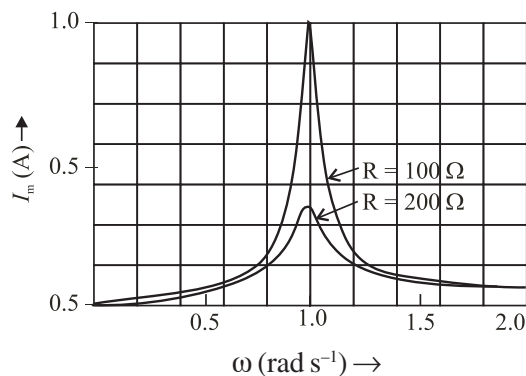

Fig.19.25 : Variation of peak current in a LCR circuit with frequency for (i) $R = 100 \Omega$, and (ii) $R = 200 \Omega$

The phenomenon of resonance in LCR circuits is utilised to tune our radio/TV receivers to the frequencies transmitted by different stations. The tuner has an inductor and a variable capacitor. We can change the natural frequency of the LC circuit by changing the capacitance of the capacitor. When natural frequency of the tuner circuit matches the frequency of the transmitter, the intercepting radio waves induce maximum current in our receiving antenna and we say that particular radio/TV station is tuned to it.



Notes

Power in a LCR Circuit

You know that a capacitor connected to an ac source reversibly stores and releases electric energy. There is no net energy delivered by the source. Similarly, an inductor connected to an ac source reversibly stores and releases magnetic energy. There is no net energy delivered by the source. However, an ac generator delivers a net amount of energy when connected to a resistor. Hence, when a resistor, an inductor and a capacitor are connected in series with an ac source, it is still only the resistor that causes net energy transfer. We can confirm this by calculating the power delivered by the source, which could be a generator.

The instantaneous power is the product of the voltage and the current drawn from the source. Therefore, we can write

$$P = VI$$

On substituting for V and I , we get

$$\begin{aligned} P &= V_m \cos \omega t \left[\frac{V_m}{Z} \cos (\omega t + \phi) \right] \\ &= \frac{V_m^2}{Z} \cdot \frac{2 \cos \omega t \cos (\omega t + \phi)}{2} \\ &= \frac{V_m^2}{2Z} \left[\cos \phi + \cos \left(\omega t + \frac{\phi}{2} \right) \right] \end{aligned} \quad (19.30)$$

The phase angle ϕ and angular frequency ω play important role in the power delivered by the source. If the impedance Z is large at a particular angular frequency, the power will be small at all times. This result is consistent with the idea that impedance measures how the combination of elements impedes (or limits) ac current. Since the average value of the second term over one cycle is zero, the average power delivered by the source to the circuit is given by

$$\text{Average Power} = \frac{V_m^2}{2Z} \cos \phi \quad (19.31)$$

$$= \frac{V_m}{\sqrt{2}} \cdot \frac{V_m}{\sqrt{2Z}} \cos \phi = V_{\text{rms}} I_{\text{rms}} \cos \phi \quad (19.32)$$

MODULE - 5

Electricity and Magnetism



Notes

Electromagnetic Induction and Alternating Current

$\cos\phi$ is called *power factor* and is given by

$$\cos\phi = \frac{R}{Z} = \frac{R}{\sqrt{R^2 + (X_L - X_C)^2}} \quad (19.33)$$

The power factor delimits the maximum average power per cycle provided by the generator. In a purely resistive circuit (or in a resonating circuit where $X_L =$

X_C), $Z = R$, so that $\cos\phi = \frac{R}{R} = 1$. That is, when $\phi = 0$, the average power dissipated per cycle is maximum: $P_m = V_{\text{rms}} I_{\text{rms}}$.

On the other hand, in a purely reactive circuit, i.e., when $R = 0$, $\cos\phi = 0$ or $\phi = 90^\circ$ and the average power dissipated per cycle $P = 0$. That is, the current in a pure inductor or pure capacitor is maintained without any loss of power. Such a current, therefore, is called *wattless current*.

19.4 POWER GENERATOR

One of the most important sources of electrical power is called **generator**. A generator is a device that converts mechanical energy into electrical energy with the help of magnetic field. No other source of electric power can produce as large amounts of electric power as the generator. A conductor or a set of conductors is rotated in a magnetic field and voltage is developed across the rotating conductor due to electromagnetic induction. The energy for the rotation of the conductors can be supplied by water, coal, diesel or gas or even nuclear fuel. Accordingly, we have hydro-generators, thermal generators, and nuclear reactors, respectively.

There are two types of generators

- alternating current generator or A.C. generator also called alternators.
- direct current generator or D.C. generator or dynamo.

Both these generators work on the principle of electromagnetic induction.

19.4.1 A.C. Generator or Alternator

A generator basically consists of a loop of wire rotating in a magnetic field. Refer to Fig. 19.26. It shows a rectangular loop of wire placed in a uniform magnetic field. As the loop is rotated along a horizontal axis, the magnetic flux through the loop changes. To see this, recall that the magnetic flux through the loop, as shown in Fig. 19.26, is given by

$$\phi(t) = \mathbf{B} \cdot \hat{\mathbf{n}}A$$

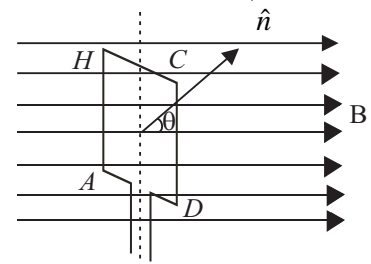

Fig. 19.26 : A loop of wire rotating in a magnetic field.



Notes

where \mathbf{B} is the field, $\hat{\mathbf{n}}$ is a unit vector normal to the plane of the loop of area A . If the angle between the field direction and the loop at any instant is denoted by θ , $\phi(t)$ can be written as

$$\phi(t) = AB \cos\theta$$

When we rotate the loop with a constant angular velocity ω , the angle θ changes as

$$\theta = \omega t \quad (19.34)$$

$$\therefore \phi(t) = AB \cos \omega t$$

Now, using Faraday's law of electromagnetic induction, we can calculate the emf induced in the loop :

$$\varepsilon(t) = -\frac{d\phi}{dt} = \omega AB \sin \omega t \quad (19.35)$$

The emf induced across a coil with N number of turns is given by

$$\begin{aligned} \varepsilon(t) &= N \omega AB \sin \omega t \quad (19.35a) \\ &= \varepsilon_0 \sin \omega t \end{aligned}$$

That is, when a rectangular coil rotates in a uniform magnetic field, the induced emf is sinusoidal.

An A.C. generator consists of four main parts (see in Fig.19.27 : (i) Armature, (ii) Field magnet, (iii) Slip-rings, (iv) Brushes.

An armature is a coil of large number of turns of insulated copper wire wound on a cylindrical soft iron drum. It is capable of rotation at right angles to the magnetic field on a rotor shaft passing through it along the axis of the drum. This drum of soft iron serves two purpose : it supports the coil, and increases magnetic induction through the coil. A field magnet is provides to produce a uniform and permanent radial magnetic field between its pole pieces.

Slip Rings provide alternating current generated in armature to flow in the device connected across them through brushes. These are two metal rings to which the two ends of the armatures are connected. These rings are fixed to the shaft. They are insulated from the shaft as well as from each other. Brushes are two flexible metal or carbon rods [B_1 and B_2 (Fig. 19.27)], which are fixed and constantly in touch with revolving rings. It is with the help of these brushes that the current is passed on from the armature and rings to the main wires which supply the current to the outer circuit.

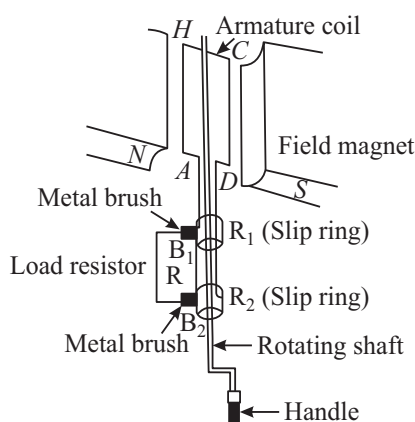

Fig.19.27 : Schematics of an ac generator

MODULE - 5

Electricity and Magnetism

Electromagnetic Induction and Alternating Current



Notes

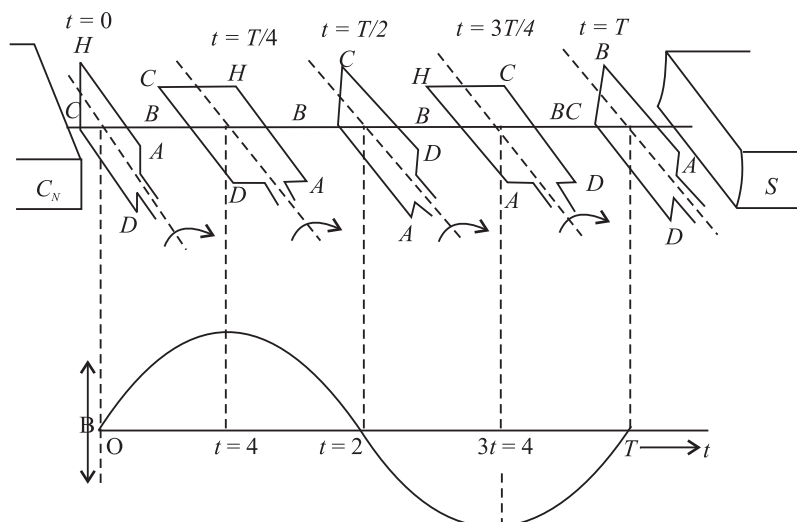

Fig. 19.28 : Working principle of an ac generator

The principle of working of an ac generator is illustrated in Fig.19.28.

Suppose the armature coil $AHCD$ rotates in the anticlockwise direction. As it rotates, the magnetic flux linked with it changes and the current is induced in the coil. The direction of the induced current is given by Fleming's right hand rule. Considering the armature to be in the vertical position and its rotation in anticlockwise direction, the wire AH moves downward and DC moves upwards, the direction of induced emf is from H to A and D to C i.e., in the coil it flows along $DCHA$. In the external circuit the current flows along $B_1 R B_2$ as shown in Fig.19.28(a). This direction of current remains the same during the first half turn of the armature. However, during the second half revolution (Fig.19.28(b)), the wire AH moves upwards while the wires CD moves downwards. The current flows in the direction $AHCD$ in the armature coil i.e., the direction of induced current in the coil is reversed. In the external circuit direction is $B_2 R B_1$. Therefore, the direction of the induced emf and the current changes after every half revolution in the external circuit also. Hence, the current thus produced alternates in each cycle (Fig. 19.28(c)).

The arrangement of slip rings and brushes creates problems of insulation and sparking when large output powers are involved. Therefore, in most practical generators, the field is rotated and the armature (coil) is kept stationary. In such a generator, armature coils are fixed permanently around the inner circumference of the housing of the generator while the field coil pole pieces are rotated on a shaft within the stationary armature.

19.4.2 Dynamo (DC Generator)

A dynamo is a machine in which mechanical energy is changed into electrical energy in the form of direct current. You must have seen a dynamo attached to a bicycle for lighting purpose. In automobiles, dynamo has a dual function for lighting



Notes

and charging the battery. The essential parts of dynamo are (i) field magnet, (ii) armature, (iii) commutator split rings and (iv) brushes.

Armatures and field magnets differ in dynamo and alternator. In the dynamo, the field magnets are stationary and the armature rotates while in an alternator, armature is stationary (stator) and the field magnet (rotor) rotates.

In a dynamo, ac waveform or the sine wave produced by an a.c. generator is converted into d.c. form by the split ring commutator. Each half of the commutator is connected permanently to one end of the loop and the commutator rotates with the loop. Each brush presses against one segment of the commutator. The brushes remain stationary while the commutator rotates. The brushes press against opposite segments of the commutator and every time the voltage reverses polarity, the split rings change position. This means that one brush always remains positive while the other becomes negative, and a d.c. fluctuating voltage is obtained across the brushes.

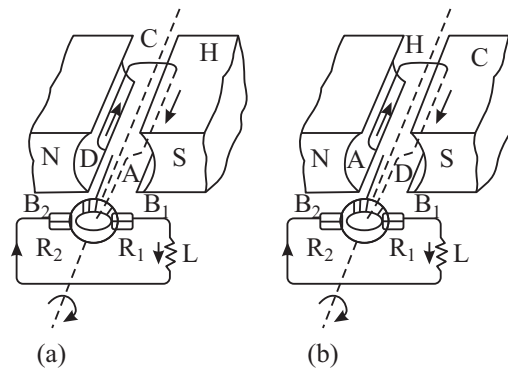

A dynamo has almost the same parts as an ac dynamo but it differs from the latter in one respect: In place of slip ring, we put two split rings R_1 and R_2 which are the two half of the same ring, as shown in Fig.19.29(a). The ends of the armature coil are connected to these rings and the ring rotates with the armature and changes the contact with the brushes B_1 and B_2 . This part of the dynamo is known as **commutator**.

When the coil is rotated in the clockwise direction, the current produced in the armature is a.c. but the commutator changes it into d.c. in the outer circuit. In the first half cycle, Fig.19.29(a), current flows along $DCHA$. The current in the external circuit flows along B_1LB_2 . In the second half, Fig.19.29(b), current in the armature is reversed and flows along $AHCD$ and as the

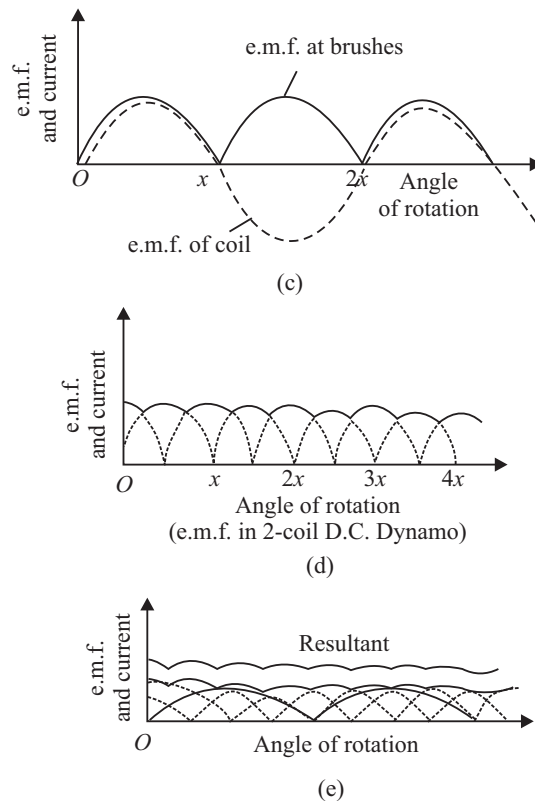

Fig. 19.29 : A dc generator

MODULE - 5

Electricity and Magnetism



Notes

Electromagnetic Induction and Alternating Current

ring R_1 comes into contact with B_1 to B_2 . Thus, current in the external circuit always flows in the same direction. The current produced in the outer circuit is graphically represented in Fig.19.29(c) as the coil is rotated from the vertical position, perpendicular to the magnetic lines of force. The current generated by such a simple d.c. dynamo is unidirectional but its value varies considerably and even falls to zero twice during each rotation of the coil.

One way of overcoming this variation would be to use two coils, mutually at right angles, and to divide the commutator ring into four sections, connected to the ends of the coils. In such a case, both these coils produce emf of the same type but they differ in phase by $\pi/2$. The resultant current or emf is obtained by superposition of the two, as shown in Fig. 19.29(d). In this way, the fluctuations are considerably reduced. Similarly, in order to get a steady current, we use a large number of coils, each consisting of good many turns. The commutator ring is divided into as many segments as the number of ends of coils, so that the coils work independently and send current into the outer circuit. The resultant current obtained is shown in Fig.19.29(e) which is practically parallel to the time axes.



INTEXT QUESTIONS 19.9

1. Distinguish between an ac and dc generator.
2. Name the essential parts of a generator?
3. Why do we use a commutator in a dc generator?
4. Where do you find the use of dynamo in daily life?

Low Voltage and Load Shedding

For normal operation of any electrical device, proper voltage is essential. If the voltage supplied by the electric supply company is less than the desired value, we face the problem of low voltage. In fact, low voltage is not as harmful to the appliance as the high voltage. However, due to **low voltage**, most of the appliances do not work properly. To overcome this, use voltage stabilizers. If the low voltage is within the range of the stabilizer, you will get constant voltage. You can use CVT (constant voltage transformers) also to get constant voltage.

As you know, the electricity generated at a power station is transmitted at high voltage to city sub-station. At the sub-station, voltage is reduced using a step down transformer. In order to avoid the danger of burning off the transformers, the supply undertakings try to keep the load on the transformer within the specified rating. If the transformer through which you receive the

voltage is heavily loaded (more than the specified value), the supplier will either shed the load by cutting the supply from the power source, or request the consumers to decrease the load by switching off the (heating or cooling) appliances of higher wattages. This process is known as **load shedding**.

In case of load shedding, you can use inverters. Inverters are low frequency oscillator circuits which convert direct current from battery to alternating current of desired value and frequency (230V and 50Hz).



Notes

19.5 TRANSFORMER

Transformer is a device that changes (increases or decreases) the magnitude of alternating voltage or current based on the phenomenon of electromagnetic induction. A transformer has at least two windings of insulated copper wire linked by a common magnetic flux but the windings are electrically insulated from one another. The transformer windings connected to a supply source, which may be an ac main or the output of a generator, is called **primary winding**. The transformer winding connected to the load R_L is called the secondary winding. In the secondary winding, emf is induced when a.c. is applied to the primary. The primary and secondary windings, though electrically isolated from each other, are magnetically coupled with each other.

Basically, a transformer is a device which transfers electric energy (or power) from primary windings to secondary windings. The primary converts the changing electrical energy into magnetic energy. The secondary converts the magnetic energy back into electric energy.

An ideal transformer is one in which

- the resistance of the primary and secondary coils is zero;
- there is no flux leakage so that the same magnetic flux is linked with each turn of the primary and secondary coils; and
- there is no energy loss in the core.

Fig. 19.30 illustrates the configuration of a typical transformer. It consists of two coils, called primary and secondary, wound on a core (transformer). The coils, made of insulated copper wire, are wound around a ring of iron made of isolated laminated sheets instead of a solid core. The laminations minimize eddy currents in iron. Energy loss in a transformer can be reduced by using the laminations of “soft” iron for the core and thick high conductivity wires for the primary and secondary windings.

MODULE - 5

Electricity and Magnetism



Notes

Electromagnetic Induction and Alternating Current

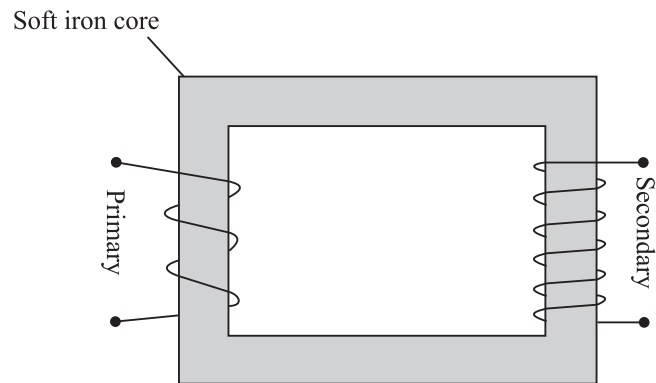

Fig.19.30 : A schematic representation of a transformer

We now discuss the working of a transformer in the following two cases:

(a) **Secondary an open circuit** : Suppose the current in the primary changes the flux through the core at the rate $d\phi/dt$. Then the induced (back) emf in the primary with N_p turns is given by

$$E_p = -N_p \frac{d\phi}{dt}$$

and the induced emf in the secondary windings of N_s turns is

or
$$E_s = -N_s \frac{d\phi}{dt}$$

$$\frac{E_p}{E_s} = \frac{N_p}{N_s} \quad (19.36)$$

(b) **Secondary not an open circuit** : Suppose a load resistance R_L is connected across the secondary, so that the secondary current is I_s and primary current is I_p . If there is no energy loss from the system, we can write

$$\text{Power input} = \text{Power output}$$

or
$$E_p I_p = E_s I_s$$

so that
$$\frac{I_p}{I_s} = \frac{E_s}{E_p} = \frac{N_p}{N_s} = k. \quad (19.37)$$

Thus when the induced emf becomes k times the applied emf, the induced current is $\frac{1}{k}$ times the original current. In other words, what is gained in voltage is lost in current.

19.5.1 Types of transformers

There are basically two types of transformers.

(i) A **step-up transformer** increases the voltage (decreases the current) in secondary windings. In such transformers (Fig.19.31a) the number of turns in secondary is more than the number of turns in primary.

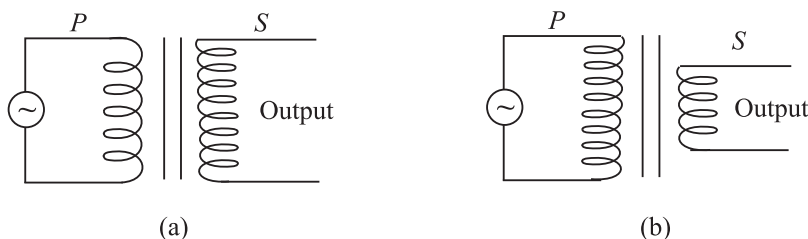

Fig. 19.31 : Iron cored a) step-up, and b) stepdown transformers

(ii) A **step-down transformer** decreases the voltage (increases the current) in the secondary windings. In such transformers (Fig 19.31b), the number of turns in secondary is less than the number of turns in the primary.

19.5.2 Efficiency of Transformers

While discussing the theory of the transformers we considered an ideal transformer in which there is no power loss. But in practice, some energy is always converted into heat in the core and the windings of the transformer. As a result, the electrical energy output across the secondary is less than the electrical energy input. The efficiency of a transformer is given by

$$\eta = \frac{\text{Energy output}}{\text{Energy input}} \times 100\%$$

$$= \frac{\text{Power output}}{\text{Power input}} \times 100\%$$

The efficiency of a transformer is less than 100%.

In a transformer the energy losses result from

- Resistive heating in copper coils - *copper loss*,
- Eddy current losses in form of heating of iron core - *Eddy current loss*.
- Magnetization heating of the core during repeated reversal of magnetization - *hysteresis loss*.
- Flux leakage from the *core*.



Notes



Notes

Electrical Power Transmission

You have learnt how electricity is generated using ac or dc generators. You must have come across small units of generating sets in shops, offices and cinema halls. When power goes off, the mains is switched over to generator. In commercial use, generators which produce power of million of watts at about 15kV (kilo volt) is common. These generating plants may be hundreds of kilometers away from your town. Very large mechanical power (kinetic energy) is, therefore, necessary to rotate the rotor which produces magnetic field inside enormously large coils. The rotors are rotated by the turbines. These turbines are driven by different sources of energy.

To minimise loss of energy, power is transmitted at low current in the transmission lines. For this power companies step up voltage using transformers. At a power plant, potential difference is raised to about 330kV. This is accompanied by small current. At the consumer end of the transmission lines, the potential difference is lowered using step down transformers.

You may now like to know how high potential difference used to transmit electrical power over long distances minimises current. We explain this with an example. Suppose electrical power P has to be delivered at a potential difference V by supply lines of total resistance R . The current $I = P/V$ and the loss in the lines is $I^2R = P^2R/V^2$. It means that greater V ensures smaller loss. In fact, doubling V quarters the loss.

Electrical power is, thus, transmitted more economically at high potential difference. But this creates insulation problems and raises installation cost. In a 400kV supergrid, currents of 2500 A are typical and the power loss is about 200kW per kilometer of cable, i.e., 0.02% (percent) loss per kilometer. The ease and efficiency with which alternating potential differences are stepped-up and stepped-down in a transformer and the fact that alternators produces much higher potential difference than d.c. generators (25kV compared with several thousand volts), are the main considerations influencing the use of high alternating rather than direct potential in most situations. However, due to poor efficiency and power thefts, as a nation, we lose about } Rs. 50,000 crore annually.

Example 19.7 : What is the efficiency of a transformer in which the 1880 W of primary power provides for 1730 W of secondary power?

Solution : Given $P_{\text{pri}} = 1880\text{W}$ and $P_{\text{sec}} = 1730\text{W}$. Hence

$$\text{Efficiency} = \frac{P_{\text{sec}}}{P_{\text{pri}}} \times 100$$

$$\therefore = \frac{1730\text{W}}{1880\text{W}} \times 100 = 92\%$$

Thus, the transformer is 92% efficient.

Example 19.8 : A transformer has 100 turns in its primary winding and 500 turns in its secondary windings. If the primary voltage and current are respectively 120V and 3A, what are the secondary voltage and current?

Solution : Given $N_1 = 100$, $N_2 = 500$, $V_1 = 120\text{V}$ and $I_1 = 3\text{A}$

$$V_2 = \frac{N_2}{N_1} \times V_1 = \frac{500\text{turns}}{100\text{turns}} \times 120\text{V} = 600\text{V}$$

$$I_2 = \frac{N_1}{N_2} \times I_1 = \frac{100\text{turns}}{500\text{turns}} \times 3\text{A} = 0.6\text{A}$$



Notes



INTEXT QUESTIONS 19.10

1. Can a transformer work on dc? Justify your answer.
2. Why does step-up transformer have more turns in the secondary than in the primary?
3. Is the secondary to primary current ratio same as the secondary to primary voltage ratio in a transformer?
4. Toy trains often use a transformer to supply power for the trains and controls. Is this transformer step-up or step-down?



WHAT YOU HAVE LEARNT

- A current is induced in a coil of wire if magnetic flux linking the surface of the coil changes. This is known as the phenomenon of **electromagnetic induction**.
- The induced emf ε in a single loop is given by **Faraday's law**:

$$e = \frac{d\phi_B}{dt}$$

where ϕ_B is the magnetic flux linking the loop.

- According to **Lenz's Law**, the induced emf opposes the cause which produces it.

MODULE - 5

Electricity and Magnetism



Notes

Electromagnetic Induction and Alternating Current

- Induced closed loops of current are set up on the body of the conductor (usually a sheet) when it is placed in a changing magnetic field. These currents are called eddy currents.
- If the current changes in a coil, a self-induced emf exists across it.
- For a long, tightly wound solenoid of length ℓ , cross-sectional area A , having N number of turns, the self-inductance is given by

$$L = \frac{\mu_0 N^2 A}{\ell}$$

- Current in an LR circuit takes some time to attain maximum value.
- The changing currents in two nearby coils induce emf mutually.
- In an LC circuit, the charge on the capacitor and the current in the circuit oscillate sinusoidally with the angular frequency ω_0 given by

$$\omega_0 = \frac{1}{\sqrt{LC}}$$

- In an ac circuit, the voltage across the source is given by $V = V_m \cos \omega t$ and current $I = I_m \cos (\omega t + \phi)$
- In a purely resistive ac circuit, the voltage and current are in phase.

The average power in such a circuit is $P_{av} = \frac{I_m^2 R}{2}$

- In a purely capacitive ac circuit, the current leads the voltage by 90° . The average power in such a circuit is zero.
- In a purely inductive ac circuit, the current lags the voltage by 90° . The average power in such a circuit is zero.

- In a series LCR circuit, $I_m = \frac{V_m}{Z} = \frac{V_m}{[R^2 + (X_L - X_C)^2]^{1/2}}$,

where Z is the impedance of circuit : $Z = [R^2 + (X_L - X_C)^2]^{1/2}$

- For $X_L - X_C = 0$, an ac circuit is purely resistive and the maximum current $I_m = V_m/R$. The circuit is said to be in resonance at $\omega_0 = 1/\sqrt{LC}$.
- The average power $P_{av} = V_{rms} \cdot I_{rms} = I_{rms}^2 R$.
- A generator converts mechanical energy into electrical energy. It works on the principle of electromagnetic induction.



- A transformer is a static electrical device which converts an alternating high voltage to low alternating voltage and vice versa.
- The transformers are of two types: Step-up to increase the voltage, and Step-down : to decrease the voltage.
- The secondary to primary voltage ratio is in the same proportion as the secondary to primary turns ratio i.e.

$$\frac{V_s}{V_p} = \frac{N_s}{N_p}$$

- Main sources of power losses in a transformer are heating up of the windings and eddy current
- For transmission of power from a power station to our homes, transformers and transmission lines are used.



TERMINAL EXERCISES

1. Each loop in a 250-turn coil has face area $S = 9.0 \times 10^{-2} \text{ m}^2$. (a) What is the rate of change of the flux linking each turn of the coil if the induced emf in the coil is 7.5V? (b) If the flux is due to a uniform magnetic field at 45° from the axis of the coil, calculate the rate of change of the field to induce that emf.
2. (a) In Fig.19.32 what is the direction of the induced current in the loop when the area of the loop is decreased by pulling on it with the forces labelled F? B is directed into the page and perpendicular to it.
 (b) What is the direction of the induced current in the smaller loop of Fig.19.31b when a clockwise current as seen from the left is suddenly established in the larger loop, by a battery not shown?

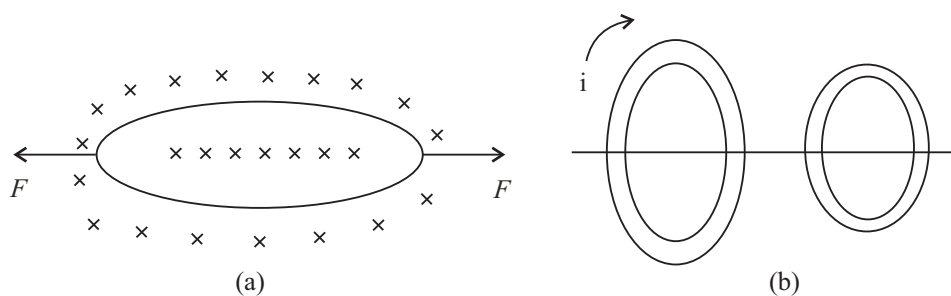

Fig. 19.32

MODULE - 5

Electricity and Magnetism



Notes

Electromagnetic Induction and Alternating Current

3. (a) If the number of turns in a solenoid is doubled, by what amount will its self-inductance change?
(b) Patrol in a vehicle's engine is ignited when a high voltage applied to a spark plug causes a spark to jump between two conductors of the plug. This high voltage is provided by an ignition coil, which is an arrangement of two coils wound tightly one on top of the other. Current from the vehicle's battery flows through the coil with fewer turns. This current is interrupted periodically by a switch. The sudden change in current induces a large emf in the coil with more turns, and this emf drives the spark. A typical ignition coil draws a current of 3.0 A and supplies an emf of 24kV to the spark plugs. If the current in the coil is interrupted every 0.10ms, what is the mutual inductance of the ignition coil?
4. (a) Why is the rms value of an ac current always less than its peak value?
(b) The current in a $2.5\mu\text{F}$ capacitor connected to an ac source is given by $I = -4.71 \sin 377t \mu\text{A}$
Calculate the maximum voltage across the capacitor.
5. (a) Calculate the capacitive reactance (for $C = 2 \mu\text{F}$) and the inductive reactance (for $L = 2 \text{ mH}$) at (i) 25Hz and (ii) 50Hz.
(b) Calculate the maximum and rms currents in a $22 \mu\text{H}$ inductor connected to a 5V (rms) 100MHz generator.
6. A series LCR circuit with $R = 580\Omega$, $L = 31 \text{ mH}$, and $C = 47 \text{ nF}$ is driven by an ac source. The amplitude and angular frequency of the source are 65 V and 33 krad/s. Determine (a) the reactance of the capacitor, (b) the reactance of the inductor, (c) the impedance of the circuit, (d) the phase difference between the voltage across the source and the current, and (e) the current amplitude. Does current lead behind or lag the voltage across the source?
7. What is electromagnetic induction? Explain Faraday's laws of electromagnetic induction.
8. State Lenz's law. Show that Lenz's law is a consequence of law of conservation of energy.
9. What is self-induction? Explain the physical significance of self-inductance.
10. Distinguish between the self-inductance and mutual-inductance. On what factors do they depend?
11. How much e.m.f. will be induced in a 10H inductor in which the current changes from 10A to 7A in $9 \times 10^{-2}\text{s}$?
12. Explain why the reactance of a capacitor decreases with increasing frequency, whereas the reactance of an inductor increases with increasing frequency?
13. What is impedance of an LCR series circuit? Derive an expression for power dissipated in a.c. LCR circuit.



14. Suppose the frequency of a generator is increased from 60Hz to 120Hz. What effect would this have on output voltage?
15. A motor and a generator basically perform opposite functions. Yet some one makes a statement that a motor really acts as a motor and a generator at the same time? Is this really true?
16. A light bulb in series with an A.C. generator and the primary winding of a transformer glows dimly when the secondary leads are connected to a load, such as a resistor, the bulb in the primary winding will brighten, why?
17. If the terminals of a battery are connected to the primary winding of transformer, why will a steady potential differences not appear across the secondary windings.
18. The power supply for a picture tube in a colour television (TV) set typically requires 15,000V A.C. How can this potential difference be provided if only 230V are available at a household electric outlet?
19. Would two coils acts as transformer without an iron core? If so, why not omit the core to save money?
20. An ac source has a 10-volt out-put. A particular circuit requires only a 2V A.C. input. How would you accomplish this? Explain.
21. A person has a single transformer with 50 turns on one part of the core and 500 turns on the other. Is this a step-up or a step-down transformer? Explain.
22. Some transformers have various terminals or “taps” on the secondary so that connecting to different tap puts different functions of the total number of secondary windings into a circuit? What is the advantage of this?
23. A transformer in an electric welding machine draws 3A from a 240V A.C. power line and delivers 400A. What is the potential difference across the secondary of the transformer?
24. A 240-V, 400W electric mixer is connected to a 120-V power line through a transformer. What is the ratio of turns in the transformer? and How much current is drawn from the power line?
25. The primary of a step-up transformer having 125 turns is connected to a house lighting circuit of $220 V_{ac}$. If the secondary is to deliver 15,000 volts, how many turns must it have?
26. The secondary of a step-down transformer has 25 turns of wire and primary is connected to a 220V ac. line. If the secondary is to deliver 2.5 volt at the out-put terminals, how many turns should the primary have?
27. The primary of a step-down transformer has 600 turns and is connected to a 120V ac line. If the secondary is to supply 5 volts at its terminal and electron current of 3.5A, find the number of turns in the secondary and the electron current in the primary?

MODULE - 5

Electricity and Magnetism



Notes

Electromagnetic Induction and Alternating Current

28. A step-up transformer with 352 turns in the primary is connected to a 220V ac line. The secondary delivers 10,000 volts at its terminal and a current of 40 milliamperere.
- How many turns are in the secondary?
 - What is the current in the primary?
 - What power is drawn from the line?



ANSWERS TO INTEXT QUESTIONS

19.1

1. $N = 1000$, $r = 5 \times 10^{-2}\text{m}$ and $B_1 = 10\text{T}$ $B_2 = 0\text{T}$

a) For $t = 1\text{s}$,

$$\begin{aligned} |e| &= N \frac{(B_2 - B_1)}{t} \pi r^2 \\ &= 10^3 \times \frac{10 \times \pi \times 25 \times 10^{-4}}{1} \\ &= 25\pi\text{V} \\ &= 25 \times 3.14 = 78.50\text{V} \end{aligned}$$

b) For $t = 1\text{ms}$

$$\begin{aligned} |e| &= \frac{10^3 \times 10\pi \times 25 \times 10^{-4}}{10^{-3}} \\ &= 78.5 \times 10^3\text{V} \end{aligned}$$

2. Since $\phi = A + Dt^2$, $e_1 = \frac{d\phi}{dt} = 2Dt$

$$\begin{aligned} \therefore e &= Ne_1 = 2N Dt \\ &= 2 \times 250 \times 15t = 7500t \end{aligned}$$

For $t = 0$, $e_1 = 0$ and hence $e = 0\text{V}$

For $t = 3\text{s}$, $e = 22500\text{V}$

3. $\phi = \mathbf{B} \cdot \mathbf{S} = BS \cos\theta$



$$|e| = N \frac{d\phi}{dt}$$

$$|e| = \left| NS \frac{dB}{dt} \cos \theta \right| \because \theta \text{ is constt}$$

(a) $|e|$ is max.

when $\cos \theta = 1$, $\theta = 0$, i.e., The coil is normal to the field.

(b) $|e|$ is min.

when $\theta = 90$, i.e. coil surface is parallel to the field.

19.2

1. As we look on the coil from magnet side Anticlockwise for both A and B .
2. In all the loops except loop E there is a change in magnetic flux. For each of them the induced current will be anticlockwise
3. Yes, there is an induced current in the ring. The bar magnet is acted upon by a repulsive force due to the induced current in the ring.
4. To minimise loss of energy due to eddy currents.

19.3

$$\begin{aligned} 1. \quad e &= L \frac{dI}{dt} = \omega \frac{N^2 A}{\ell} \frac{(I_2 - I_1)}{t} \\ &= \frac{4\pi \times 10^{-7} \times \pi \times 10^{-2} \times (2.5 - 0)}{1 \times 10^{-3}} \\ &= 10^{-6} \text{ V} \end{aligned}$$

2. Because, current in the two parallel strands flow in opposite directions and oppose the self induced currents and thus minimize the induction effects.

$$\begin{aligned} 3. \quad 3.5 \times 10^{-3} &= 9.7 \times 10^{-3} \times \frac{dI}{dt} \\ &= \frac{dI}{dt} = \frac{3.5}{9.7} = 0.36 \text{ A s}^{-1} \end{aligned}$$

19.4

1. Because, the inductor creates an inertia to the growth of current by inducing a back emf

MODULE - 5

Electricity and Magnetism



Notes

Electromagnetic Induction and Alternating Current

$$2. \quad 2.2 \times 10^{-3} = \frac{L}{R}$$

$$\Rightarrow L = 2.2 \times 68 \times 10^{-3} \text{H} \\ = 150 \text{mH}$$

19.5

- (a) If i_1 is increasing, the flux emerging out of the first coil is also increasing. Therefore, the induced current in the second coil will oppose this flux by a current flowing in clockwise sense as seen by O . Therefore B will be positive and A negative.
(b) If i_2 is decreasing, flux emerging out of the first coil is decreasing. To increase it the induced current should flow in out anticlockwise sense leaving C at positive potential and D at negative.
- No, the mutual inductance will decrease. Because, when the two coils are at right angles coupling of flux from one coil to another coil will be the least.

19.6

- It actually does but we can not detect it, because the frequency of our domestic ac is 50Hz. Our eye can not detect changes that take place faster than 15 times a second.

$$2. \quad (i) \quad I_{\text{rms}} = \frac{E_{\text{rms}}}{R} = \frac{220 \text{ V}}{25 \text{ } \Omega} = 8.8 \text{ A.}$$

$$(ii) \quad \text{Peak value of current } I_m = \sqrt{2} I_{\text{rms}} = 1.4 \times 8.8 = 12.32 \text{ A.}$$

$$\text{Instantaneous current} = I_0 \sin 2\pi\nu t \\ = 12.32 \sin 100\pi t$$

(iii) Average value of current over integral number of cycles will be zero.

- Since an ac current varies sinusoidally, its average value over a complete cycle is zero but rms value is finite.

19.7

- Capacitive reactance $X_C = \frac{1}{2\pi\nu C}$. As C increases X_C decreases and I increases.
- A charged capacitor takes some time in getting discharged. As frequency of source increases it starts charging the capacitor before it is completely



discharged. Thus the maximum charge on capacitor and hence maximum current flowing through the capacitor increases though V_m is constant.

3. Because the energy stored in the capacitor during a charging half cycle is completely recovered during discharging half cycle. As a result energy stored in the capacitor per cycle is zero.
4. Capacitive reactance $X_C = \frac{1}{2\pi\nu C}$ as ν increases X_C decreases. This is so because on capacitor plates now more charge accumulates.

19.8

1. In accordance with Lenz's law a back emf is induced across the inductor when ac is passed through it. The back emf $e = -L \frac{dI}{dt}$.
2. $I_{\text{rms}} = \frac{V_{\text{rms}}}{X_L}$ frequency increases, $X_L (= 2\pi\nu L)$ increases, hence I_{rms} decreases.

19.9

1. (i) The a.c. generator has slip rings whereas the d.c. generator has a split rings commutator.
(ii) a.c. generator produces current voltage in sinusoidal form but d.c. generator produces current flowing in one direction all through.
2. Four essential parts of a generator are armature, field magnet, slip rings and brushes.
3. The commutator converts a.c. wave form to d.c. wave form.
4. Attached to the bicycle for lighting purpose.

19.10

1. No, because the working of a transformer depends on the principle of electromagnetic induction, which requires time varying current.
2. Because the ratio of the voltage in primary and secondary coils is proportional to the ratio of number of their turns.
3. No, they are reciprocal to each other.
4. Step-down transformer.

Answers To Problems in Terminal Exercise

1. (a) $3 \times 10^{-2} \text{ W}_b \text{ s}^{-1}$ (b) 0.47 T s^{-1}
4. (b) $5 \times 10^{-2} \text{ V}$

MODULE - 5

Electricity and Magnetism



Notes

Electromagnetic Induction and Alternating Current

5. (a) (i) $\frac{1}{\pi} \times 10^4 \Omega$ (ii) $\frac{1}{2\pi} \times 10^4 \Omega$
(b) (i) $0.1 \pi \Omega$ (ii) $0.2 \pi \Omega$
6. (a) $6.7 \times 10^2 \Omega$ (b) 99Ω (c) 813.9Ω (d) $\square 4 \text{ rad}$
(e) 0.16 A (f) Current lags
11. 333.3 V 23. 1.8 A .
24. $1 : 2, \frac{10}{3} \text{ A}$. 25. 8522 turns
26. 2200 turns 27. $25 \text{ turns}, \frac{1}{7} \text{ A}$.
28. (a) 16000 turns , (b) $\frac{20}{11} \text{ A}$ (c) 400 W